

Preface

Thank you for choosing SINEE's EM760 series high-performance vector inverter.

Document No.: 31010200

Release time: 2022-3

Version: 200

The EM760 series inverter is a high-performance vector control inverter launched by SINEE, which integrates the synchronous motor drive and asynchronous motor drive. It supports three-phase AC asynchronous motors and permanent magnet synchronous motors, internationally advanced drive control technologies [such as the improved vector V/F control technology (VVF), speed sensorless vector control technology (SVC) and speed sensor vector control technology (FVC)], speed output and torque output, Wi-Fi access and background software debugging, expansions (such as I/O expansion cards, communication bus expansion cards and PG cards).

The standard EM 760 supports V/F control, SVC control, FVC control of asynchronous motors; it also supports V/F control and FVC control of permanent magnet synchronous motors. The non-standard version for synchronous motors also supports V/F control, SVC control, FVC control of asynchronous motors, as well as V/F control, SVC control and FVC control of permanent magnet synchronous motors.

The EM760 series high-performance vector inverter has the following features:

- Equipment of a built-in DC reactor (in case of an inverter of above 18.5kW) can reduce input current distortion, increase the power factor and promote the product reliability;
- High torque control accuracy: SVC/±5% rated torque, FVC/±3% rated torque;
- Wide speed range and high control accuracy: SVC/1:200 (±0.2%), FVC/1:1000 (±0.02%) rated speed;
- Low-frequency carrier: VVF/3Hz/150%, SVC/0.25Hz/150%, FVC/0Hz/180%;
- Protections against overvoltage stall, fast current limit, overload, overheat, off-load, overspeed, and so on;
- Support I/O expansion: 3-channel digital inputs, 2-channel relay outputs, 1-channel -10V~10V voltage input, 1-channel sensor input;
- Support communication bus expansion: standard configuration including 485 bus, optional PROFINET, CANopen and EtherCAT;
- Support various encoders: ABZ incremental, UVW incremental, UVW wire saver, rotary transformer and sine-cosine transformer;
- Support debugging by the mobile phone APP or monitoring of the inverter status;
- Support Wi-Fi module or serial port access;
- Rich and convenient PC background software functions.

Before using the EM760 series high-performance vector inverter, please read this guide carefully and keep it properly.

While connecting the inverter to motor for the first time, please select the motor type (asynchronous or synchronous) correctly and set the motor nameplate parameters: rated power, rated voltage, rated current, rated frequency, rated speed, motor connection, rated power factor, etc. In case of FVC drive control mode, it is required to select the optional PG card and set correct encoder parameters.

We are committed to continuously improving our products and product data, so the data provided by us may be modified without prior notice.

For the latest changes and contents, please visit www.sinee.cn

Safety precautions

Safety definition: Safety precautions are divided into the following two categories in this manual:



Danger: The dangers caused by nonconforming operations may include serious injuries and even deaths.





Note: The danger caused by nonconforming operations, including moderate or minor injuries and equipment damage.



During the installation, commissioning and maintenance, please read this chapter carefully, and follow the safety precautions herein. Our company will not be liable for any injury or loss arising from nonconforming operations.

Precautions

Before installation:

 Danger
<ol style="list-style-type: none">1. Do not install the product in the case of water in the package or missing or damaged components found in unpacking!2. Do not install the product in the case of inconsistency between the actual product name and identification on the outer package.
 Warning
<ol style="list-style-type: none">1. When opening the wooden case, do wear gloves; to prevent person injuries, do not contact the sealing plate with hands!2. When handling the inverter, please hold its bottom. If you hold the front cover, the inverter body may fall down to cause injuries!3. Handle the controller with care; otherwise, it may be damaged!4. Never use the inverter damaged or with some parts missing; otherwise, injuries may be caused!5. Do not touch components of the control system with your hands; otherwise static charge may be generated to cause damage to the inverter!6. The inverter has undergone withstand voltage testing before delivery. Do not perform withstand voltage testing on your own; otherwise the inverter may be damaged!

During installation:

 Danger
<ol style="list-style-type: none">1. Please install the controller on metal or other flame-retardant objects and keep it away from combustible materials; otherwise, a fire may be caused!2. Do not loosen the fixing bolts of components, especially those with red marks!
 Warning
<ol style="list-style-type: none">1. The inverter shall not be installed in a place with conductive dust, corrosive gas, salt spray, oily dirt, condensation, vibration or direct exposure to sunlight!2. Never allow wire connectors or screws to fall into the inverter; otherwise, the inverter may be damaged!3. When the inverter is installed a relatively closed cabinet or space, pay attention to the installation gap to ensure the effects of heat dissipation.

During wiring:

 Danger
<ol style="list-style-type: none">1. Observe the instructions in this manual and make wiring done by professional electrical personnel; otherwise, electric shock may be caused!2. The inverter must be separated from the power supply by using a circuit breaker (it is recommended to use a circuit breaker of greater rated current that is the most approximate to twice the rated current of the inverter); otherwise, a fire may be caused!

3. Before wiring, make sure that the power supply is OFF (zero energy). Do not carry out wiring when the controller is powered on; otherwise, electric shock may be caused!
4. Never connect the input power supply to the output terminals (U, V, W) of the inverter. Pay attention to the marks of wiring terminals, and connect wires correctly! Otherwise, the inverter may be damaged and even a fire may be caused!
5. Ground the controller correctly and reliably as required; otherwise, electric shock may be caused!



Warning

1. Connect the output terminals (U, V, W) of the inverter to corresponding input terminals (U, V, W) of the motor. An inconsistent phase sequence will cause the motor to reverse.
2. Make sure that the lines meet the EMC requirements and local safety standards. For wire diameters, refer to the recommendations. Otherwise, an accident may occur!
3. Never connect the braking resistor directly between the DC bus + and - the terminal; otherwise the inverter may be damaged and a fire may be caused!
4. Use a screwdriver with the specified torque to tighten main circuit terminals; otherwise, a fire may occur!
5. Never connect the phase-shifting capacitor and LC/RC noise filter to the output circuit.
6. Do not connect the electromagnetic switch and electromagnetic contactor to the output circuit. Otherwise, the overcurrent protection circuit of the inverter will be enabled, and internal damage of the inverter may be incurred in severe cases.
7. Do not dismantle the connecting cable inside the inverter; otherwise, internal damage may be caused to the inverter.

Before power-on:



Danger

1. Check whether the supply voltage is consistent with the rated voltage of the inverter; otherwise, equipment damage or fire may be incurred.
2. Check whether wiring of power input terminals (R, S and T) and output terminals (U, V and W) is connected correctly;
3. Check whether there is a short circuit among the peripheral circuits connected to the inverter and whether all connected lines are tightened; otherwise, the inverter may be damaged!



Warning

1. The inverter must not be powered on until it is properly covered; otherwise, electric shock may be caused!
2. The wiring of all peripheral accessories must be in line with the instructions in this manual. All wires should be connected correctly according to the circuit connections in this manual. Otherwise, an accident may occur!

After power-on:



Danger

1. Never touch the inverter and surrounding circuits; otherwise, electric shock may occur!
2. If the indicator does not turn on or the keyboard does not display after electrification, immediately turn off the power switch; 10 minutes later, check if the wiring is connected properly. Do not touch the inverter terminals R, S and T and any power terminal by hand or with a screwdriver; otherwise, electric shock may occur! After eliminating the causes of wiring errors, contact our customer service personnel immediately.
3. Never touch any wiring terminals of the inverter after electrification; otherwise, electric shock may occur!
4. Do not disassemble any parts of the inverter while it is powered on.



Warning

1. If parameter identification is required, please pay attention to the danger of injury caused by the rotating motor. Check the safety before parameter identification; otherwise, an accident may be caused!
2. Do not change the parameters set by the inverter manufacturer without permission; otherwise, the inverter may be damaged!



During maintenance:



Danger

1. Never carry out repair and maintenance in the live state; otherwise, electric shock may be caused!
2. Maintenance of the inverter must be carried out 10 minutes after the main circuit is powered off and the display interface of the keyboard is disabled; otherwise, the residual charge in the capacitor will do harm to the human body!
3. Personnel without professional training are not allowed to repair and maintain the inverter; otherwise, personal injury or inverter damage may be caused!
4. After replacement of the inverter, it is required to set and check the parameters. Plugging and unplugging operations must be done with power disconnected!
5. The synchronous motor can rotate to generate electricity. For maintenance and repair of the inverter, it is required to wait 10 minutes after the motor stops rotation and have safety measures in place before disconnecting the motor and the inverter; otherwise, electric shock may occur!

During operation:

 Danger
<ol style="list-style-type: none">1. Do not touch the cooling fan, radiator and discharge resistor to feel the temperature; otherwise, burns may be caused!2. Non-professional technicians must not test signals when the controller is in operation; otherwise, personal injury or equipment damage may be caused!
 Warning
<ol style="list-style-type: none">1. Prevent any object from falling into the inverter in operation; otherwise, the inverter may be damaged!2. Do not start or stop the inverter by turning on or off the contactor; otherwise, the inverter may be damaged!

Precautions

Motor insulation inspection

When the motor is used for the first time or after long-term storage or subject to regular inspection, its insulation should be checked to prevent the inverter from damage caused by failure of the motor winding insulation. During the insulation inspection, the motor must be disconnected from the inverter. It is recommended to use a 500V megohmmeter. The measured insulation resistance must not be less than 5MΩ.

Thermal protection of motor

If the motor used does not match the rated capacity of the inverter, especially when the rated power of the inverter is greater than that of the motor, the motor must be protected by adjusting the motor protection parameters of the inverter or installing a thermal relay in front of the motor.

Operation above power frequency

Some inverters can provide 0.00Hz~600.00Hz/0.0Hz~3000.0Hz output frequency. When the motor needs to operate above the rated frequency, please consider the capacity of the mechanical device. Otherwise, equipment damage or even life-threatening accidents may occur.

Presence of voltage-dependent device or capacitor increasing the power factor on output side

The inverter outputs PWM waves. If there is a capacitor increasing the power factor or voltage-dependent resistor for lightning protection on the output side, the inverter may be subjected to instantaneous overcurrent and even damage. Do not use these devices.

Use beyond rated voltage

The inverter should not be used beyond the allowable working voltage range specified in this manual; otherwise, components inside the inverter are prone to damage. If necessary, use the appropriate step-up or step-down device for voltage transformation.

Lightning impulse protection

This inverter series is equipped with a surge current protection device for protection against induced lightning. In lightning-prone places, a lightning protection device should be added before the inverter.

Altitude and derating

In areas with an altitude of more than 1,000m, where heat dissipation of the inverter is poor due to thin air, derating is required (derating by 1% per 100m altitude increase to maximum 3,000m; for ambient temperature

above 50°C, derating by 1.5% per 1°C temperature rise to maximum 60°C). Contact us for technical advice.

Precautions for scrapping of inverter

Burning of the electrolytic capacitors of the main circuit and printed circuit board may result in explosion, and burning of plastic parts may generate toxic gases. Please dispose of the controller as a kind of industrial waste.

Scope of application

This product is not designed and manufactured as a device or system of vital importance. Do not use this product in these cases.

This product is manufactured under strict quality management. When failure of this product may cause a major accident or loss, please install a safety device.

Prevention of electric shock

Please read all requirements of safety precautions! Maintenance of the inverter must be carried out 10 min after the main circuit is powered off and the display interface of the keyboard is disabled; otherwise, the residual charge in the capacitor will do harm to the human body!

Anti-toppling

The cabinet has an anti-toppling label attached onto it. You may check the label upon receiving the goods to know transport condition of the goods and reject the goods if the label color has changed.

Transportation

When you select transport of the inverter in a cabinet, it is necessary to protect the whole cabinet with anti-shock measures.

TABLE OF CONTENTS

Preface	1
Safety precautions	3
Chapter 1 Overview	8
Chapter 2 Installation	11
Chapter 3 Wiring	21
Chapter 4 Keyboard Operations	30
Chapter 5 Trial Run	34
Chapter 6 Solution	41
Chapter 7 Maintenance	46
Chapter 8 Select Accessories	48
Chapter 9 Function Code Table	51

Chapter 1 Overview

1.1 Model and Specification of EM760 Series Inverter

Rated voltage of power supply: Three-phase AC 340V~460V

Applicable motor: Three-phase AC asynchronous motor and permanent magnet synchronous motor.

Rated voltage of power supply	Model	Applicable motor power (kW)	Rated output current (A)
Three-phase AC 340~460V	EM760-0R7G/1R5P-3B	0.75/1.5	2.5/4.2
	EM760-1R5G/2R2P-3B	1.5/2.2	4.2/5.6
	EM760-2R2G/3R0P-3B	2.2/3.0	5.6/7.2
	EM760-4R0G/5R5P-3B	4.0/5.5	9.4/12
	EM760-5R5G/7R5P-3B	5.5/7.5	13/17
	EM760-7R5G/9R0P-3B	7.5/9.0	17/20
	EM760-011G/015P-3B	11/15	25/32
	EM760-015G/018P-3B	15/18.5	32/38
	EM760-018G/022P-3B	18.5/22	38/44
	EM760-022G/030P-3B	22/30	45/59
	EM760-030G/037P-3/3B	30/37	60/73
	EM760-037G/045P-3/3B	37/45	75/87
	EM760-045G/055P-3/3B	45/55	90/106
	EM760-055G/075P-3/3B	55/75	110/145
	EM760-075G/090P-3/3B	75/90	150/169
	EM760-090G/110P-3	90/110	176/208
	EM760-110G/132P-3	110/132	210/248
	EM760-132G/160P-3	132/160	253/298
	EM760-160G/185P-3	160/185	304/350
	EM760-200G/220P-3	200/220	380/410
	EM760-220G/250P-3	220/250	426/456
	EM760-250G/280P-3	250/280	465/510
	EM760-280G/315P-3	280/315	520/573
	EM760-315G/355P-3	315/355	585/640
EM760-355G/400P-3	355/400	650/715	
EM760-400G/450P-3	400/450	725/810	
EM760C-450G/500P-3	450/500	820/900	
EM760C-500G/560P-3	500/560	900/1010	
EM760C-560G/630P-3	560/630	1010/1140	

Table 1-1 Technical Specifications of EM760 Series Inverter

Item		Specification
Power supply	Rated voltage of power supply	Three-phase 340V-10% to 460V+10% 50-60Hz ± 5%; voltage unbalance rate: <3%
Output	Maximum output voltage	The maximum output voltage is the same as the input power voltage.
	Rated output current	Continuous output of 100% rated current
	Maximum overload current	G model: 150% rated current for 60s P model: 120% rated current for 60s (2kHz carrier; please derate for carriers above this level)
Basic control functions	Driving mode	V/F control (VVF); Speed sensorless vector control (SVC) Speed sensor vector control (FVC)
	Input mode	Frequency (speed) input, torque input
	Start and stop	Keyboard, control terminal (two-line control and three-line control).

User's Guide for EM760 series high-performance vector inverter

	control mode	communication
	Frequency control range	0.00~600.00Hz/0.0~3000.0Hz
	Input frequency resolution	Digital input: 0.01Hz Analog input: 0.1% of maximum frequency
	Speed control range	1:50 (VVF), 1:200 (SVC), 1:1000 (FVC)
	Speed control accuracy	±0.5% (VVF), ±0.2% (SVC), ±0.02% (FVC)
	Acceleration and deceleration time	0.01s~600.00s/0.1s~6000.0s/1s~60000s
	Voltage/frequency characteristics	Rated output voltage 20%~100% adjustable, reference frequency 1Hz~600Hz/3000Hz adjustable
	Torque boost	Fixed torque boost curve, any V/F curve optional
	Starting torque	150%/3Hz (VVF), 150%/0.25Hz (SVC), 180%/0Hz (FVC)
	Torque control accuracy	±5% rated torque (SVC), ±3% rated torque (FVC)
	Self-adjustment of output voltage	When the input voltage changes, the output voltage will basically remain unchanged.
	Automatic current limit	Output current is automatically limited to avoid frequent overcurrent trips.
	DC braking	Braking frequency: 0.01 to maximum frequency Braking time: 0~30S Braking current: 0%~150% rated current
	Signal input source	Communication, multi-speed, analog, high-speed pulse, etc.
Input and output function	Reference power supply	10.5V±0.5V/20mA
	Terminal control power	24V/200mA
	Digital terminal input	7 (standard configuration X1~X7) + 3 (extension card X8~X10)-channel digital multi-function inputs: X7 can be used as a high-speed pulse input terminal (F02.06 = 35/38/40); X1~X6 and X8~X10, totally 9 terminals that can only serve as ordinary digital input terminals
	Analog terminal input	3 (standard configuration AI1 ~ AI3) + 1 (extension card AI4)-channel analog input: 1-channel AI1: support 0 ~ 10V or -10~ 10V, optional for selection by using function code F02.62; 2-channel AI2/AI3: support 0 ~ 10V or 0~ 20mA or 4~ 20mA, optional for selection by using function code F02.63 and F02.64 is optional; 1-channel AI4: support 0 ~ 10V or -10~ 10V, optional for selection by using function code F02.65
	Digital terminal output	2 (standard Y1/Y2) open-collector multi-function outputs + 2 (R1: EA/EB/EC and R2: RA/RB/RC) relay multi-function outputs + 2 (extension card) (R3: RA3/RC3 and R4: RA4/RC4) relay multi-function outputs Maximum output current of the collector: 50 mA; Relay contact capacity 250VAC/3A or 30VDC/1A, with EA-EC and RA-RC normally open, EB-EC and RB-RC normally closed; RA3-RC3, RA4-RC4 normally open
Analog terminal output	2-channel (M1/M2) multi-function analog output terminals to output 0~10V or 0~20mA or 4~20mA, optional for selection by using function codes F03.34 and F03.35	
V	LCD display	The LCD digital tube displays relevant information about the inverter.
	Parameter copying	Parameter settings of the inverter can be uploaded and downloaded for fast

User's Guide for EM760 series high-performance vector inverter

		parameter copying.
Protection	Protective Function	Short circuit, overcurrent, overvoltage, undervoltage, phase loss, overload, overheat, overspeed, load loss, external fault, etc.
Use conditions	Location	Indoor, at an altitude of less than 1 km, free of dust, corrosive gases and direct sunlight
	Applicable environment	-10°C to +50°C, derating by 5% per 1°C increase above 40°C, 20% to 90%RH (non-condensing)
	Vibration	Less than 0.5g
	Storage environment	-40°C~+70°C
	Installation method	Wall-mounted, floor-standing electrical control cabinet, through-wall
Protection level		Standard IP21/IP20 (remove the plastic cover at the top of the plastic case)
Cooling method		Forced air cooling

Chapter 2 Installation

2.1 Product check

 Warning
<ul style="list-style-type: none"> ● Never install the inverter damaged or with some parts missing. Otherwise, injuries may be caused.

When you receive the product, please check it against the table below.

Item to be confirmed	Confirming methods
Check whether the product is consistent with the order.	Check the nameplate on the side face of the inverter.
Check whether any part is damaged.	Check the overall appearance for damage caused in transportation.
Check whether the fastened parts (e.g. screws) are loose.	If necessary, check the product with a screwdriver.

In the case of any defect, contact the agent or our Marketing Department.

- **Nameplate**

<p>Model: EM760-4R0G/5R5P-3B</p> <hr/> <p>INPUT : U1: 3PH 340-460V 50/60Hz I1:11.4/15.4A</p> <p>OUTPUT : U2: 3PH 0-U1 0-600Hz I2: 9.4/12A 4.0/5.5kW</p>  <p>01182387122112230101 101</p> <p>SINEE SHENZHEN SINE ELECTRIC CO.,LTD. MADE IN CHINA</p>

- **Description of inverter model**

EM 760 - 4R0G/5R5P - 3 B

EM760:
High-performance series

Null: Installation in cabinet

TC: Cabinet type

B: Built-in braking unit
None: Without braking unit

Identification		Compatible motor type		
G		Universal model		
P		Fan pump type		
Compatible load power:				
0R7	4R0	018
0.75kW	4.0kW	18.5kW

Voltage class:
2: Three-phase 220V
3: Three-phase 380V
6: Three-phase 660V

2.2 Outline dimensions and installation dimensions

EM760 inverters have 3 types of appearance and 13 installation sizes, and may be connected with external keyboards and trays. As shown in Fig. 2-1 and Table 2-1.

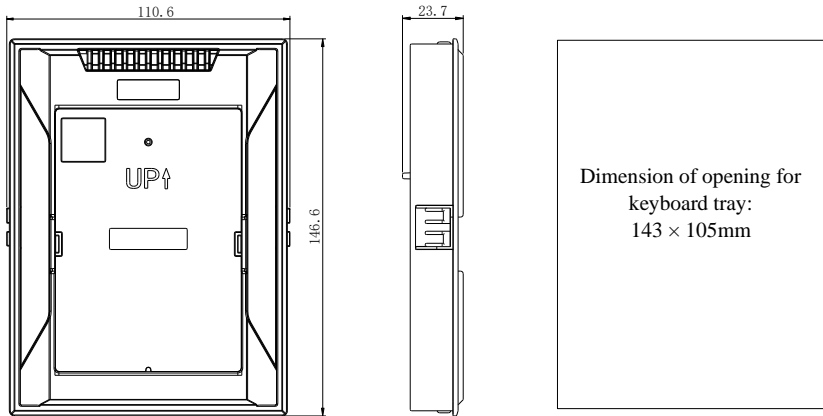

Reference size of keyboard bracket opening

(a) Dimension of keyboard tray

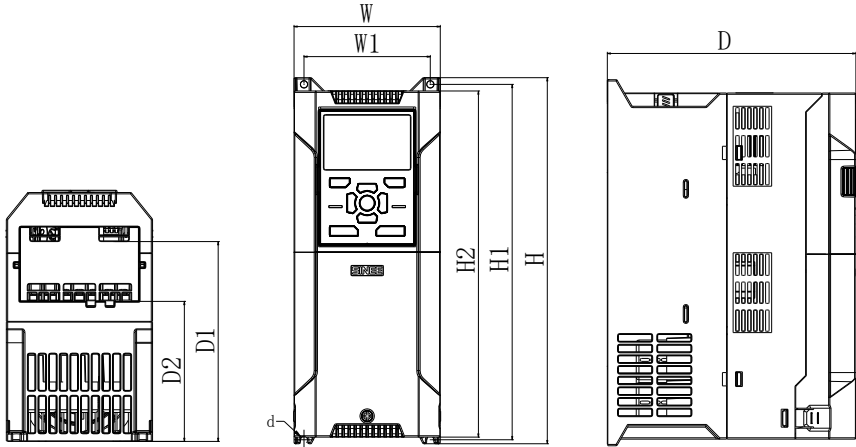

(b) Appearance of EM760-0R7G/1R5P~022G/030P inverters

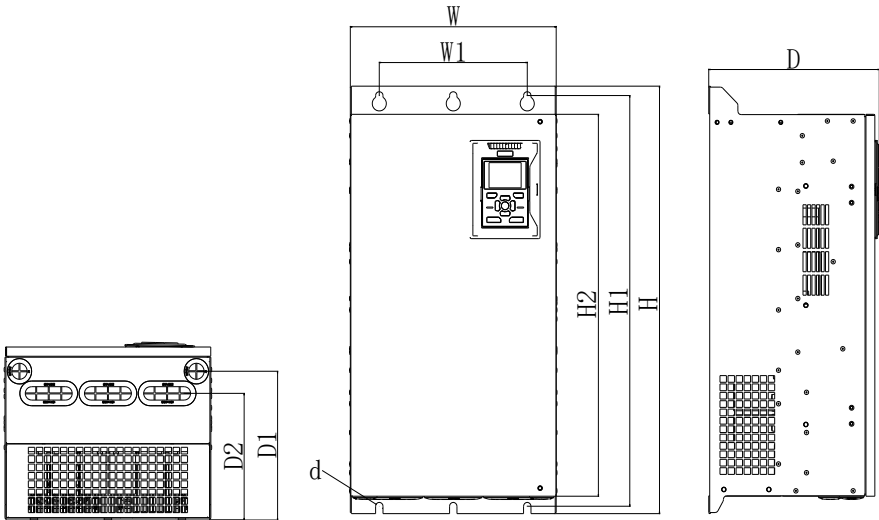

(c) Appearance of EM760-030G/037P~400G/450P inverters

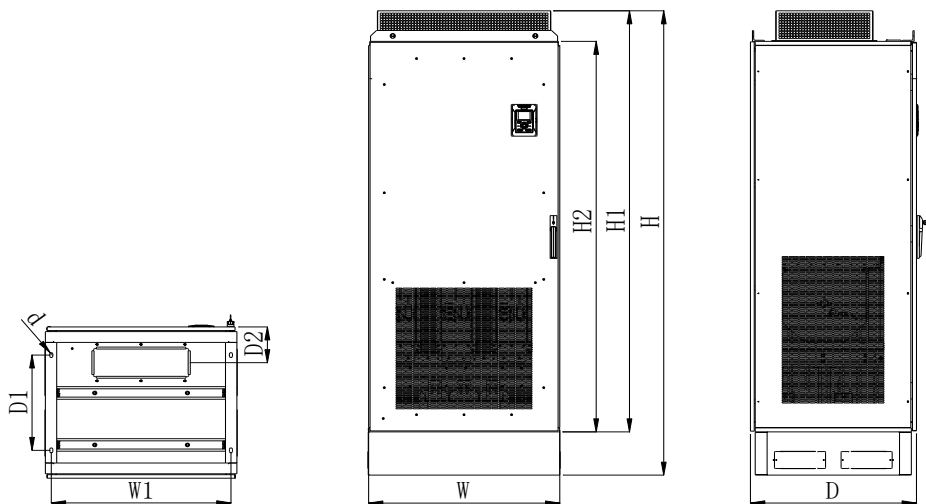

(d) Appearance of EM760- 450G/500P~560G/630P inverters

Fig. 2-1 Overall dimensions of EM760 Series Keyboard and Inverter

Table 2-1 Outer and installation dimensions of EM760 inverters

Specifications	W	W1	H	H1	H2	D	D1	D2	d	appearance
EM760-0R7G/1R5P-3B	95	82	230	222	218	171	132	96	4.5	(b)
EM760-1R5G/2R2P-3B										
EM760-2R2G/3R0P-3B										
EM760-4R0G/5R5P-3B										
EM760-5R5G/7R5P-3B	110	95	275	267	260	187	146	105	5.5	
EM760-7R5G/9R0P-3B										
EM760-011G/015P-3B	140	124	297	289	280	207	163	120	5.5	
EM760-015G/018P-3B										
EM760-018G/022P-3B	190	171	350	340	330	220	173	128	7	
EM760-022G/030P-3B										
EM760-030G/037P-3/3B	254	200	484	465	440	221	180.5	158	9.5	
EM760-037G/045P-3/3B										
EM760-045G/055P-3/3B	304	210	540	519	480	263	217	197	9.5	
EM760-055G/075P-3/3B										
EM760-075G/090P-3/3B	324	230	638	613	570	264	220	181	11.5	
EM760-090G/110P-3	339	270	623	600	578	296	243	243	11.5	
EM760-110G/132P-3										
EM760-132G/160P-3	422	320	786	758	709	335	271	256.4	11.5	
EM760-160G/185P-3										
EM760-200G/220P-3	441	320	1025	989	942	357	/	285	11.5	
EM760-220G/250P-3										
EM760-250G/280P-3	560	450	1204	1170.5	1100	400	/	333	13	
EM760-280G/315P-3										
EM760-315G/355P-3	660	443	1597	1567	1504	430	375.5	323.5	13	
EM760-355G/400P-3										
EM760-400G/450P-3										
EM760C-450G/500P-3										
EM760C-500G/560P-3	805	756	2145	1945	1804	700	440	165	13	
EM760C-560G/630P-3										

2.3 Installation Site Requirements and Management

Installation site

The installation site should meet the following conditions:

- The room is well ventilated.
- The ambient temperature is -10°C to 50°C.
- The controller should be free from high temperature and humidity (less than 90% RH) or rainwater and other liquid droplets.

- Please install the inverter on a fire-retardant object (e.g. metal). Never install it on flammable objects (e.g. wood).
- No direct sunlight.
- No flammable or corrosive gas and liquid, dust, oily dust, floating fibers or conductive dust.
- The installation foundation should be secured and vibration-free. Do not pose any obstacle within 1m behind the inverter cabinet, so as to provide some space for maintenance.
- Avoid electromagnetic interference and keep the controller away from interference sources.

Preventive measures

Take protective measures to the inverter during installation to prevent metal fragments or dust generated in drilling and other processes from falling into the inverter. Remove the protection after installation.

2.4 Installation Direction and Space

The EM760 inverters are equipped with cooling fans for forced air cooling. To ensure good cyclic cooling effects, the inverter must be installed in a vertical direction, and sufficient spaces must be reserved between the inverter and adjacent objects or baffles (walls). Refer to Fig. 2-2.

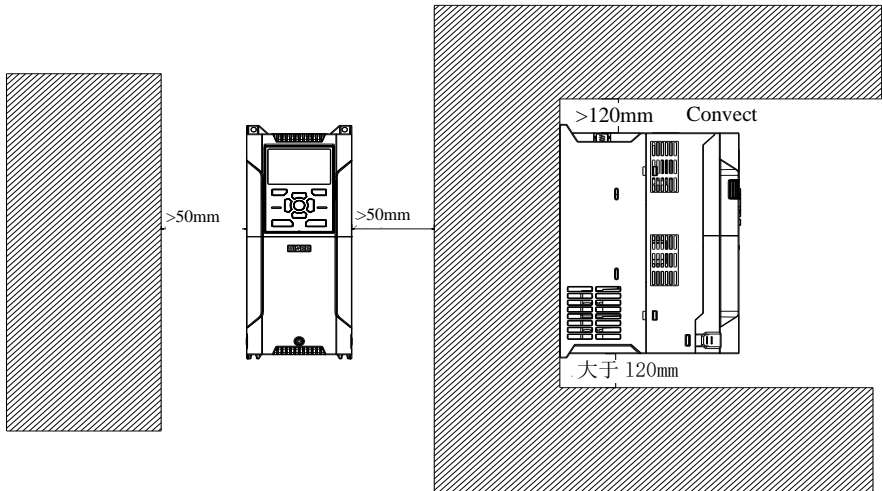

Fig. 2-2 Inverter installation direction and space

2.5 Panel removal and installation

Wiring of the main circuit, control circuit and expansion card for the EM760 Series requires removal of the top cover. When wiring is completed, install the wiring ducts and top cover in the reverse order of removal.

- (1) EM760 0R7G/1R5P-022G/030P panel removal

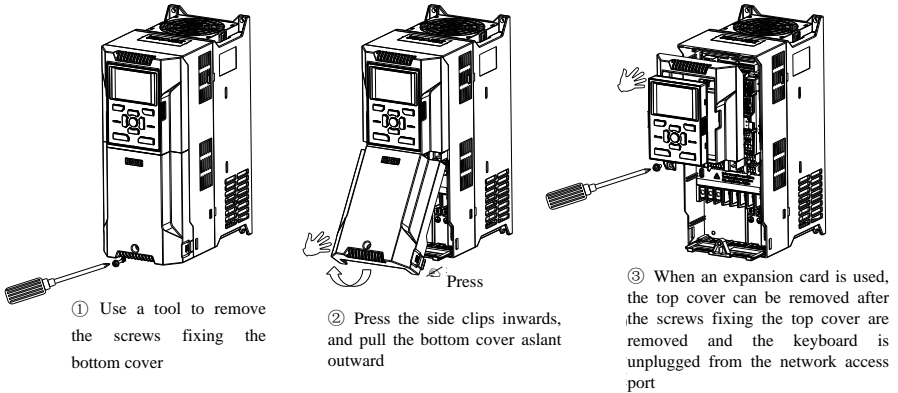

Fig. 2-3 EM760-0R7G/1R5P-022G/030P panel removal diagram

(2) EM760 030G/037P~400G/450P panel removal

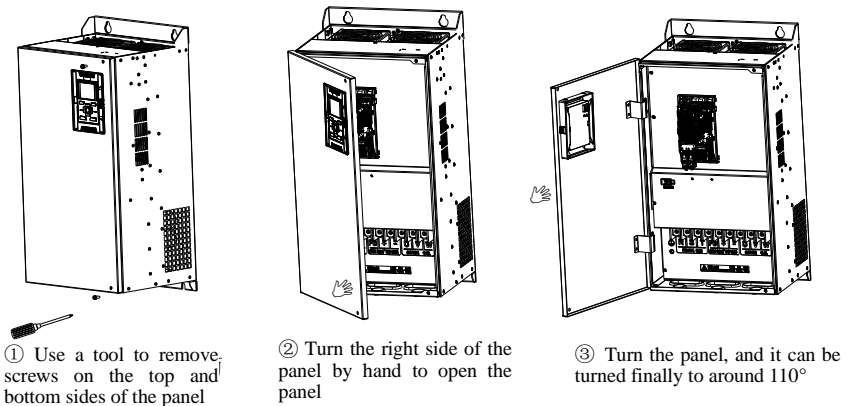

Fig. 2-4 EM760-030G/037P~400G/450P panel removal diagram

2.6 Through-wall installation

EM760 0R7G/1R5P~160G/185P support through-wall installation, which can realize dissipating 70% of the total heat generated out of the device (cabinet), so as to reduce heat accumulation. Besides, through-wall installation may also prevent entry of wood chips, paper scraps, dust, metal dust and other debris into the inverter and improve reliability of the inverter.

The bracket for through-wall installation is available as an optional part for purchase. If it is needed, please contact us.

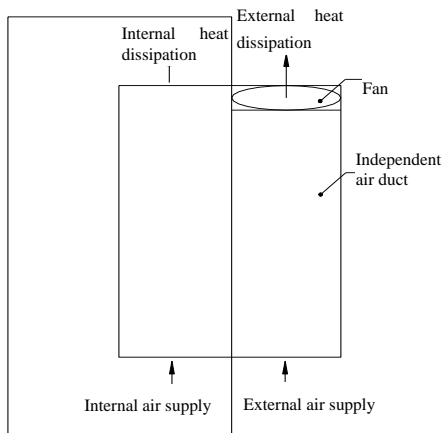

Fig. 2-5 Through-wall installation

Table 2-2 Number of screws and opening dimension for EM760 0R7G/1R5P~160G/185P through-wall installation

Frequency converter model	Bracket installation screws	Through-wall installation screws	Opening size (L×W)
EM760-0R7G/1R5P~4R0G/5R5P-3B	2×M4	6×M6	235mm×100mm
EM760-5R5G/7R5P~7R5G/9R0P-3B	2×M4	6×M6	280mm×115mm
EM760-011G/015P~015G/018P-3B	2×M4	6×M6	300mm×145mm
EM760-018G/022P~022G/030P-3B	4×M4	6×M6	355mm×195mm
EM760-030G/037P~037G/045P-3/3B	14×M5	6×M8	500mm×265mm
EM760-045G/055P~055G/075P-3/3B	14×M5	6×M8	550mm×320mm
EM760-075G/090P-3/3B	14×M5	6×M10	645mm×340mm
EM760-090G/110P~110G/132P-3	14×M5	6×M10	630mm×350mm
EM760-132G/160P~160G/185P-3	13×M6	6×M10	715mm×440mm

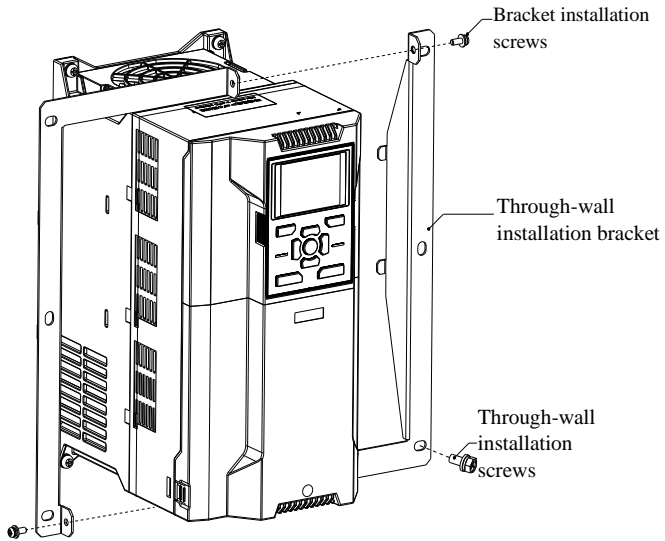

Fig. 2-6 Through-wall installation diagram of EM760-0R7G/1R5P~022G/030P

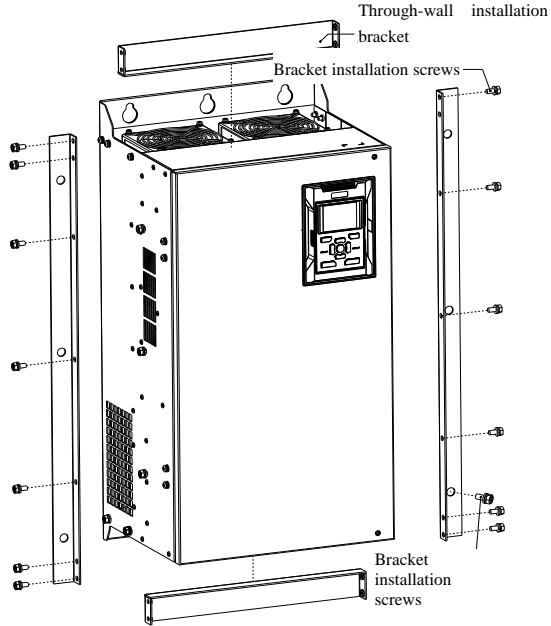

Fig. 2-7 Through-wall installation diagram of EM760-030G/037P~110G/132P

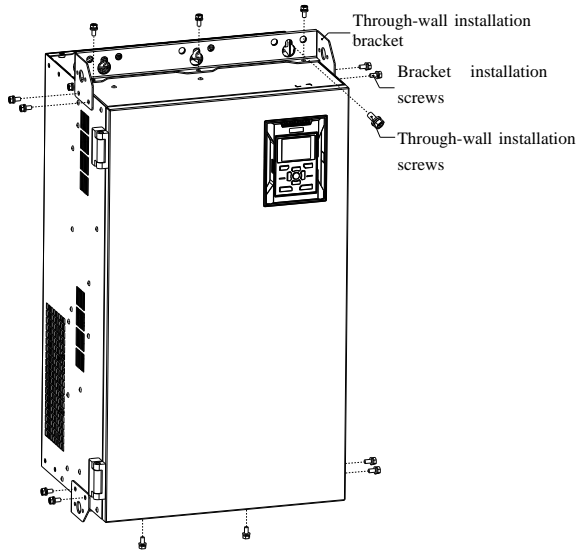

Fig. 2-8 Through-wall installation diagram of EM760-132G/160P~160G/185P

Chapter 3 Wiring

3.1 Connection of Peripheral Device

The standard connection between the EM760 series inverter and peripheral devices is shown in Fig. 3-1.

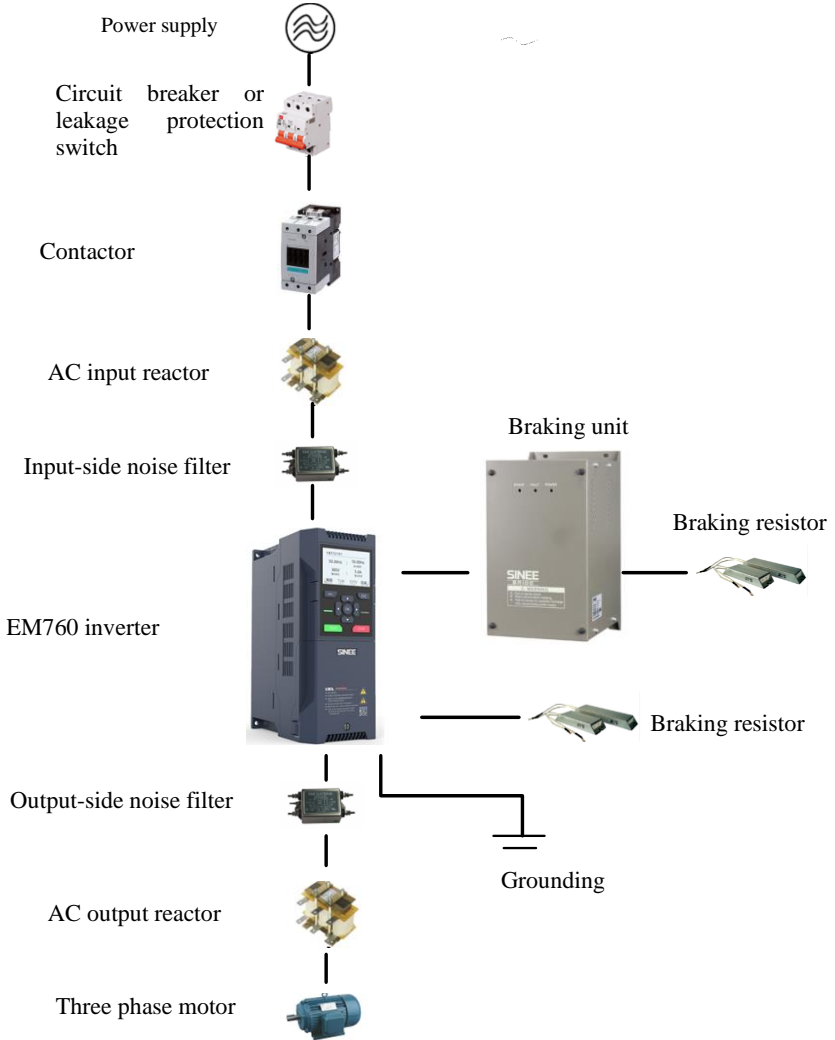
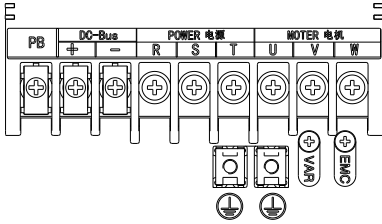

Fig. 3-1 Connection of Inverter and Peripheral Devices

3.2 Wiring of Main Circuit Terminal

3.2.1 Composition of main circuit terminal



(a) 0.75-22kW main circuit terminal

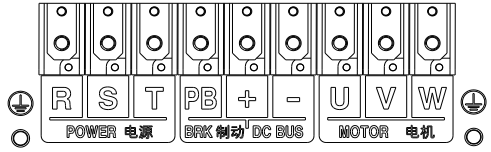

(b) 30-75kW main circuit terminal (-3 series have no PB terminal)

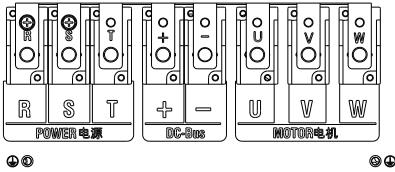

(c) 90-110kW main circuit terminal

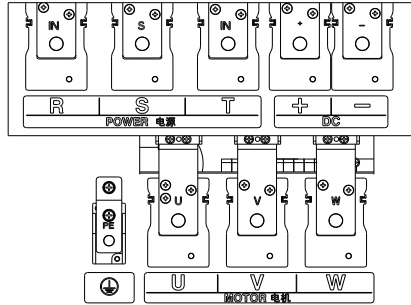

(d) 132-220kW main circuit terminal

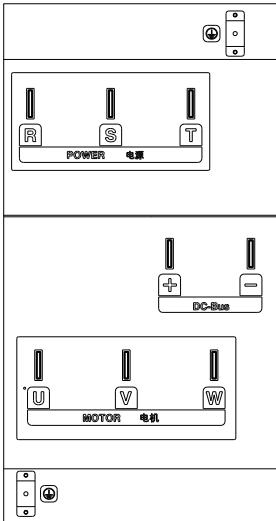

(e) 250-400kW main power terminal

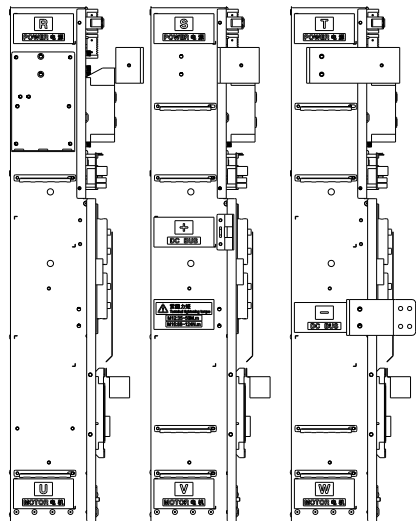

(f) 450-560kW main power terminal

Fig. 3-2 Schematic Diagram of Main Circuit Terminal Layout

As shown in Fig. 3-3, wiring of 0.75~22kW inverters may be conducted with the gate on the cable protector removed in case of a large-sized cable.

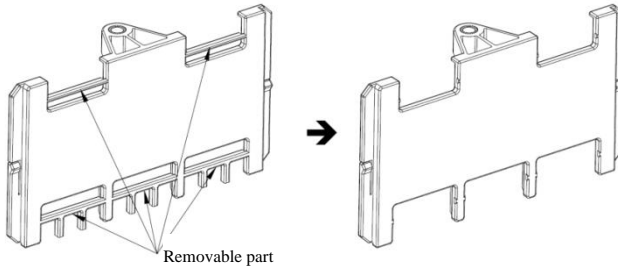

Fig. 3-3 Cable protector

3.2.2 Functions of main circuit terminals

Table 3-1 Functions of Main Circuit Terminals

Terminal label	Function description
R, S, T	AC power input terminal, connected to three-phase AC power supply
U, V, W	AC output terminal of the inverter, connected to three-phase AC motor
\oplus \ominus	Positive and negative terminals of the internal DC bus, connected to external braking unit
\oplus , PB	Braking resistor terminal, with one end of the braking resistor connected to \oplus and the other end to PB
\ominus	Grounding terminal, connected to earth

The standard wiring diagram of the main circuit of the EM760 series inverter is shown in Fig. 3-4.

- EM760-0R7G/1R5P-3B~EM760-075G/090P-3B EM760-030G/037P-3~EM760C-560G/630P-3

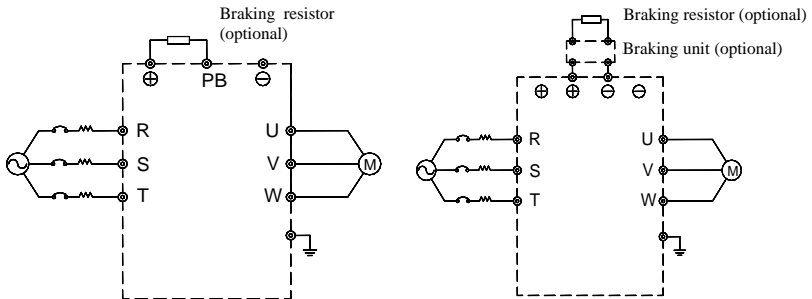

Fig. 3-4 Standard wiring of the main circuit

3.2.3 Input side wiring of main circuit

Measures against interference

The working principle of the inverter determines that it will cause external interference. Please configure the peripheral devices of the inverter as shown in Fig. 3-1. Install the filter and inverter on the same iron plate, and

shield the inverter and its peripheral device with iron boxes to reduce external interference. Refer to Fig. 3-5 for the wiring requirements. For more detailed measures to reduce external interference, refer to the EM760 User's Manual.

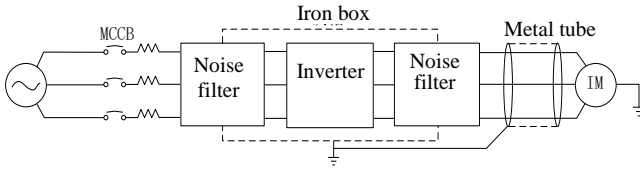

Fig. 3-5 Measures for Reduction of External Interference

Cable and screw dimensions of main circuit

For cable size and terminal screw specifications, refer to the user manual for EM760.

Installation and wiring of braking resistor and braking unit

For dynamic braking during operation, it is required to select a braking resistor and a braking unit following Chapter 8.

For the inverter with a built-in braking unit, connect the braking resistor between the inverter terminal (+) and PB terminal. For the inverter with no built-in braking unit, connect the terminals (+ and -) of the braking unit to those (+ and -) of the DC bus of the inverter, and the braking resistor to the PB+ and PB- terminals of the braking unit. Refer to the user manual of the BR100 braking unit for more information.

3.3 Wiring of Control Circuit Terminal

3.3.1 Composition of control circuit terminal

The layout of control circuit terminals is shown in Fig. 3-6.

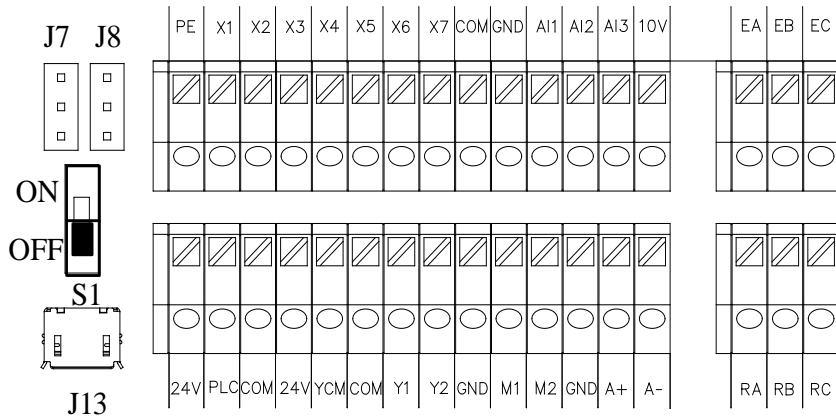

Fig. 3-6 Layout of Control Circuit Terminals

3.3.2 Functions and wiring of control circuit terminals

The functions of control circuit terminals are shown in the table below.

Category	Terminal label	Terminal name	Terminal function description
Auxiliary power supply	10V-GND	+10V power supply	Supply +10.5±0.5V power to external devices. Maximum output current: 20mA

User's Guide for EM760 series high-performance vector inverter

	24V-COM	+24V power supply	Supply +24V power to external devices. It is usually used as the working power supply for digital input and output terminals and also the power supply for external devices. Maximum output current: 200mA
	PLC	Multi-functional common input terminal	Delivery with default connection to 24V When an external power source drives the digital input terminal, it is required to disconnect the 24V terminal and connect the external power source
Analog input	AI1-GND	Analog input terminal 1	Input voltage range: DC -10~10V/0~10V, optional for selection by using function code F02.62
	AI2-GND	Analog input terminal 2	Input range: DC 0~10V/0~20mA/4~20mA; AI2 can be selected by using function code F02.63; AI3 can be selected by using function code F02.64
	AI3-GND	Analog input terminal 3	
Digital input port	X1-COM	Multi-function input terminal 1	Optocoupler isolation, compatible with NPN and PNP bipolar input Input impedance: 4kΩ Input voltage range: 9~30V
	X2-COM	Multi-function input terminal 2	
	X3-COM	Multi-function input terminal 3	
	X4-COM	Multi-function input terminal 4	
	X5-COM	Multi-function input terminal 5	
	X6-COM	Multi-function input terminal 6	
	X7-COM	High-speed pulse input terminal	Apart from using as a multi-functional input terminal, it can also be used as a high-speed pulse input terminal; the maximum response frequency: 100kHz, Input voltage: 12~30V, Input impedance: 2kΩ
Analog output	M1-GND	Analog output terminal 1	Output range: DC 0~10V/0~20mA/4~20mA; M1 can be selected by using function code F03.34; M2 can be selected by function code F03.35
	M2-GND	Analog output terminal 2	Output range: DC 0~10V/0~20mA/4~20mA, optional for selection by using function code F03.35
Multi-function output	Y1-YCM	Open output terminal of collector	Optocoupler isolation, open output of the collector Maximum output voltage: DC30V, Output current: 50mA
	Y2-COM	High-speed pulse output terminal	Optocoupler isolation, open output of the collector Maximum output voltage: DC30V Maximum output current: 50mA As a high-speed pulse output, the maximum output frequency is: 100kHz
Relay output	R1: EA-EB-EC	Relay output terminal	EA-EC: Normally open EB-EC: Normally closed
	R2: RA-RB-RC		RA-RC: Normally open RB-RC: Normally closed
Communication	A+	RS-485 communication terminal	positive terminal of 485 differential signal
	A-		negative terminal of 485 differential signal
Shield	PE	Shield earthing	Used for earthing of the terminal wiring shielding layer

3.4 Wiring of analog input terminal

3.4.1 Wiring of AI1, AI2 and AI3 terminals with analog voltage signal:

When analog voltage signal input is selected for terminal AI1 and the function code is set to F02.62 (0/3), corresponding input is (0~10V/-10~10V)

When analog voltage signal input is selected for terminal AI2 and the function code is set to F02.63 (0), corresponding input is (0~10V)

When analog voltage signal input is selected for terminal AI3 and the function code is set to F02.64 (0), corresponding input is (0~10V)

When the analog voltage input signal is powered by an external power source, wiring of AI1, AI2 and AI3 are performed as shown in the following Figure (a).

When the analog voltage input signal is a potentiometer, the wiring of AI1, AI2 and AI3 terminals is as shown in Figure (b).

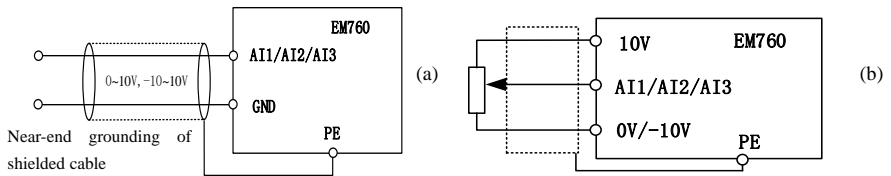

3.4.2 Wiring of AI2 and AI3 terminals with analog current signal input:

When analog current signal input is selected for terminals AI2 and AI3, and the function code is set to F02.63 (1/2) and F02.64 (1/2)

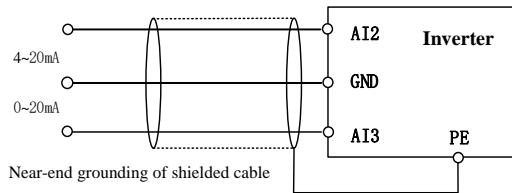

Wiring of multi-function input terminal

The multi-functional input terminal of the EM760 inverter has a full-bridge rectifier circuit. The PLC terminal is a common terminal of X1 to X7, through which the current may be forward (NPN mode) or reverse (PNP mode). Thus, the external connection of the terminals X1 to X7 is flexible. Typical wiring is shown in Fig. 3-7.

A. Use of internal power supply (+24Vdc) in NPN mode B. Use of internal power supply (+24Vdc) in PNP mode

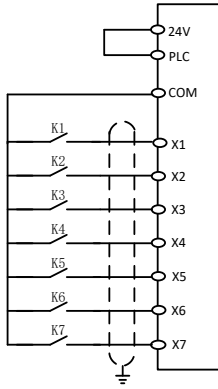

C. Use of external power supply in NPN mode

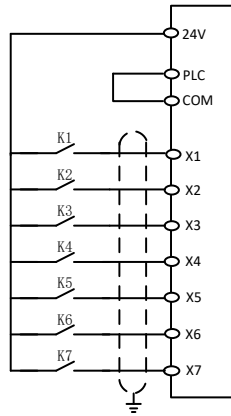

D. Use of external power supply in PNP mode

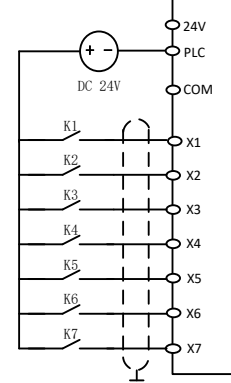
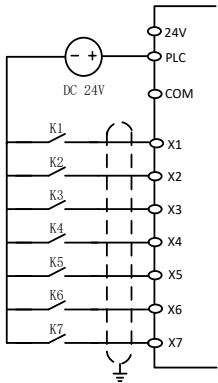
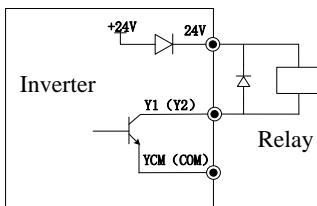

Fig. 3-7 Wiring Diagram of Multi-function Input Terminals

Note: When an external power source is used, do remove the short connection line between the 24V power source and the PLC terminal.

Wiring of multi-function output terminals

The multi-function output terminals Y1 and Y2 can be powered on by the internal 24V power supply of the inverter or an external power supply, as shown in Fig. 3-8:



a: Use of internal power supply

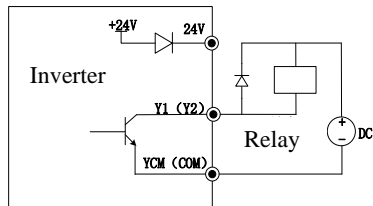

b: Use of external power supply

Fig. 3-8 Wiring of Multi-function Output Terminals

Note: The relay wire package must include anti-parallel diodes. The components of the absorption circuit should be installed close to both ends of the relay or contactor coil.

Wiring of analog output terminals

The analog output terminals (M1 and M2) can be connected with external analog meters to represent multiple physical quantities, which are optional for selection by using F03.34 or F03.35.

Wiring of 485 communication terminals

The communication terminals A+ and A- are the RS485 communication interfaces of the inverter. The online control of the host (PC or PLC controller) and inverter is performed through the connection and communication with the host. Connections of the RS485 and RS485/RS232 adapters to EM760 inverter are shown in Fig. 3-9, Fig. 3-10 and Fig. 3-11.

- Direct connection of the RS485 terminal of a single inverter to the host for communication:

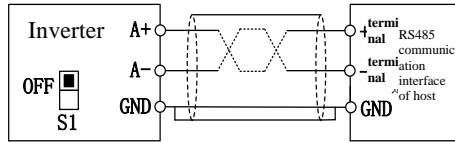

Fig. 3-9 Communication Terminal Wiring of Single Inverter

- Connection of the RS485 terminals of multiple inverters to host for communication:

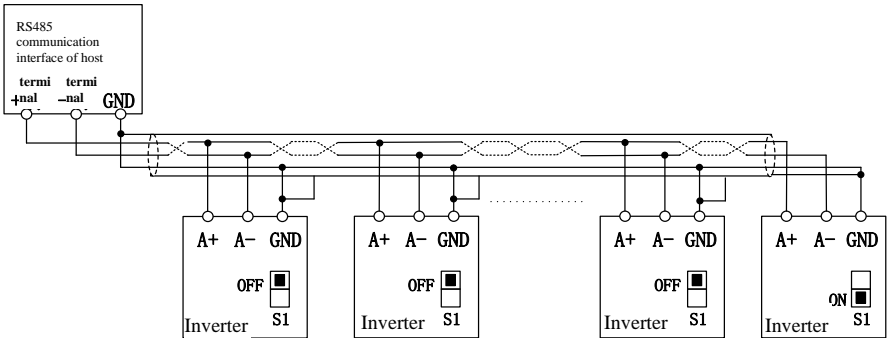

Fig. 3-10 Wiring of Communication Terminals of Multiple Inverters

Standard Wiring Diagram of Control Circuit

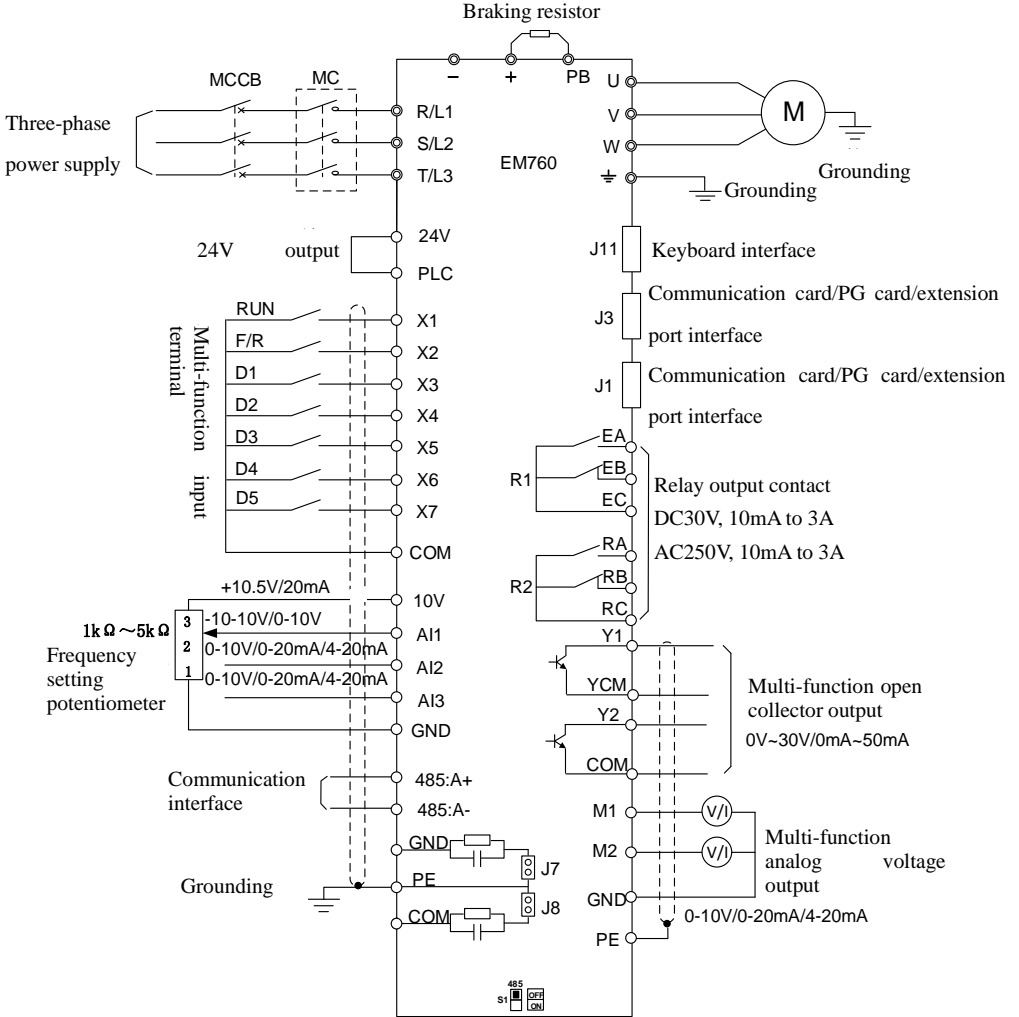

Fig. 3-11 Standard Wiring Diagram of Control Circuit

3.4.3 Extension wiring of keyboard

- 1) The external keyboard port is an RJ45 port, with an ordinary network cable (plug connection according to EIA/TIA568B) used as the extension line.
- 2) Connect RJ45 port of the keyboard to RJ45 port on the keyboard mounting plate by using a network cable.
- 3) The keyboard extension cable should be no longer than 30m. When Cat5E wire is used in sound electromagnetic environments, an extension cable of up to 50m may be purchased from the company.

Chapter 4 Keyboard Operations

4.1 Keyboard Functions

Structure of LCD keyboard

EM760 inverters may have two kinds of control panels: LED keyboard and LCD keyboard.

The LED keyboard consists of an LCD display, nine operation keys, and two status indicators.







Users can perform parameter setting, status monitoring and start/stop of the inverter via the keyboard.



4.2 LCD Keyboard Operation

The LCD keyboard menu is divided into monitoring (Level 0), menu mode selection (Level 1), the function code selection (Level 2) and the detailed function code (Level 3) from low to high. The menu levels are represented by numbers in subsequent text of this manual.

Menu mode selection has 6 options: **full menu mode** displays all function codes; **user-defined mode** displays only function codes of user group F11; **non-default mode** displays only the function codes that differ from the default settings; **fault query** allows the user to view the latest three fault records saved; **guide mode** allows setting motor parameters-related function codes in order for self-learning operation; **system setting** allows setting the brightness, backlight time, language and view of the software version

When the keyboard is powered on, it shows the level 1 menu, i.e. the monitoring interface (main monitor), by default. On the monitoring interface (main monitor) press the LEFT key  to switch the function code displayed in the second line and press the RIGHT key  to switch the function code displayed in the third line; the function codes for switching is set by using F12.33-F12.37; in the level 1 menu, press the ESC key  to enter level 0 menu; in the level 0 menu, use the LEFT key  and the RIGHT key  to select a different menu mode. In the level 0 menu, press the ESC key  to go back to the main monitoring interface of level 1 menu. The procedure for menu mode selection is shown in the figure below.

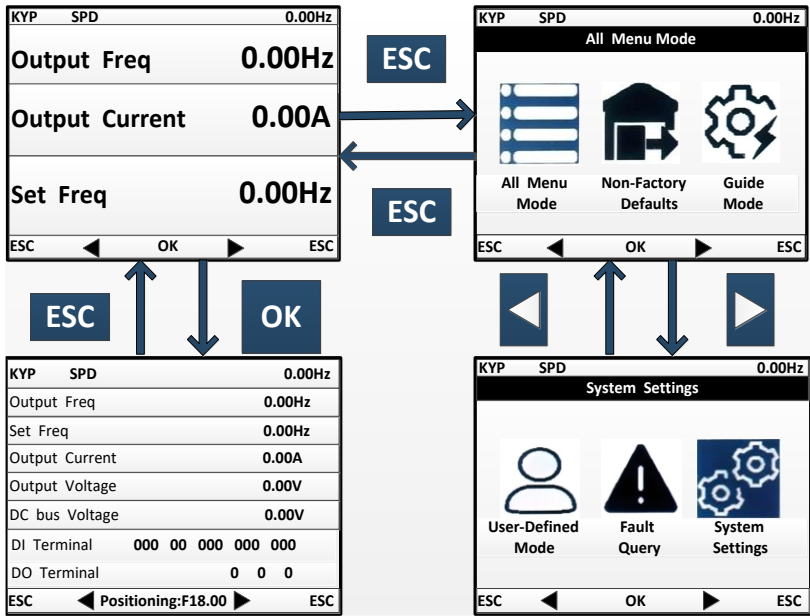

Full menu mode

In the full menu mode, press the ENTER key **OK** to enter the Level 2 menu and select any function code. Then press the ENTER key **OK** to enter the Level 3 menu and view or modify the function code. Except for a few special ones, the function codes needed by general users can be modified.

In all menu modes, the user needs to press the ENTER key **OK** to save parameter modifications.

In the Level 3 menu, press the ESC key **ESC** to abandon parameter modifications: if the function code is equal to the unmodified value, directly exit the Level 3 menu and go back to the Level 2 menu; otherwise, the unmodified value will be restored and displayed, and the user can press the ESC key **ESC** to exit the Level 3 menu and go back to the Level 2 menu.

Quick positioning function: The full menu mode displays all groups of function codes and quick positioning can facilitate operations. To locate a function code, it is only required to set the function code to display and press the ENTER key **OK** to display the function code.

The process of changing the value of the function code F03.02 to 10 from the initial status upon power-on in the full menu mode is shown in the following figure. In level 2 menu, the number of function code groups can be known through the function code progress indication. As shown in the following figure, 02/36 means group F03 consists of 36 function codes, and the cursor is currently located at F03.02.

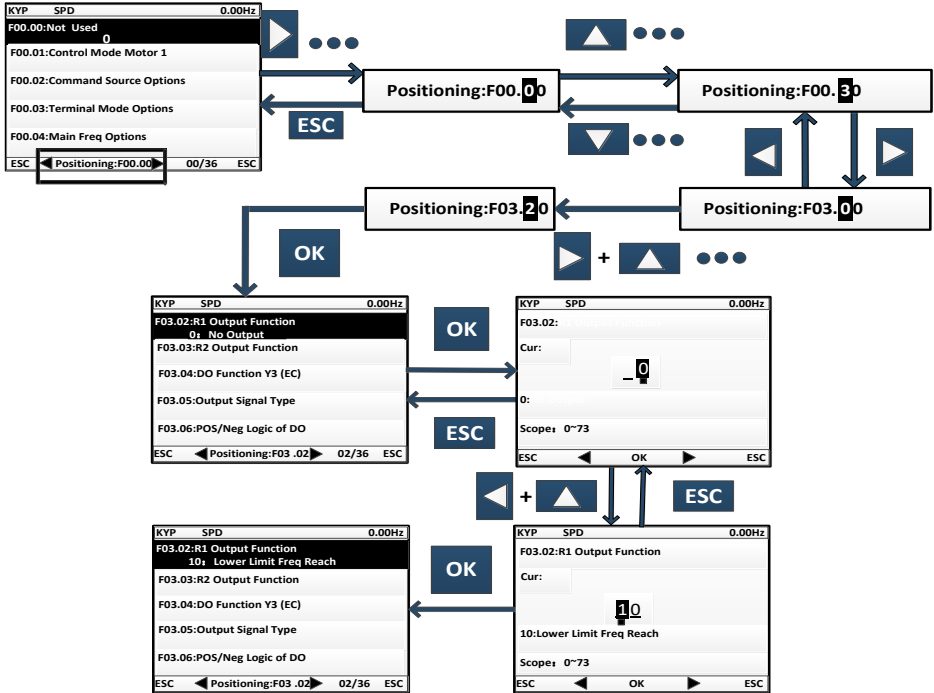

For details of other modes, see the User's Manual

4.3 Parameter copying

For convenient parameter setting between inverters using the same function parameters, the keyboard is provided with parameter uploading and downloading functions. When function code F12.03 is set to 1 and ENTER is pressed **OK** for confirmation, inverter-related parameters will be uploaded to the keyboard; upon uploading, the keyboard shows the progress; when uploading is completed, the value of the function code will automatically change to 0. The keyboard with uploading completed may be inserted into another inverter that needs to use the same parameters. Once the keyboard is inserted, you may change the value of the function code F12.03 to 2 and download the parameters to the inverter. If you set the value of the function code to 3, motor parameters will be downloaded in addition to normal parameters. Upon downloading, the keyboard will show the progress. Similarly, upon completion of parameter downloading, the value of the function code will automatically change to 0.

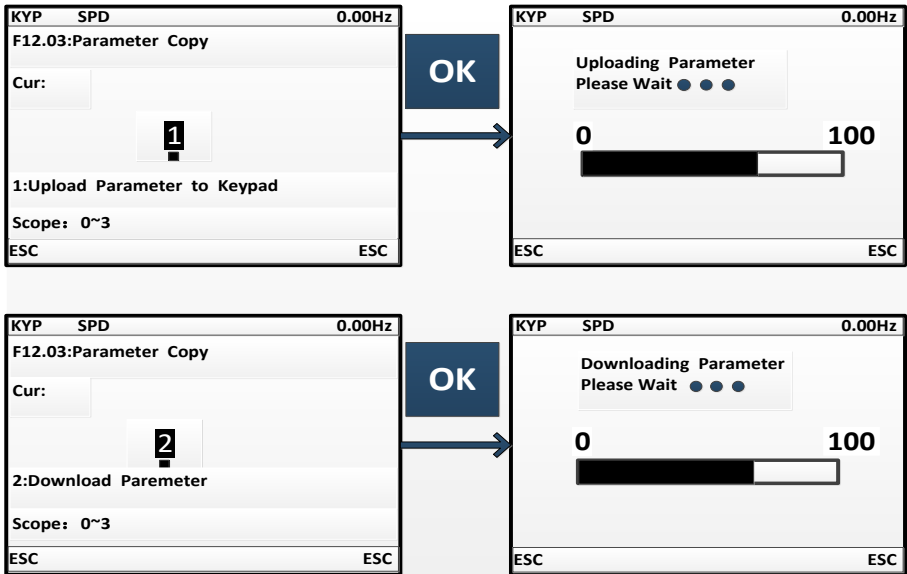

It shall be particularly noted that:

1. No keyboard can be used for parameter downloading before it undergoes parameter uploading, as unknown parameters in the keyboard without parameter uploading may cause failure of an inverter by disturbing existing parameters in the inverter. If a keyboard is used for parameter downloading without parameter uploading, it will prompt presence of no parameter in the keyboard, suggesting parameter downloading is unsuccessful; press ECS to exit; perform uploading again before downloading.
2. For parameter downloading to an inverter with a different version of CPUS software, the keyboard will prompt whether to continue downloading regardless of the different version; at this time, it is required to make clear whether parameter downloading is permitted between the two different versions. If yes, press ENTER key **OK** to execute the downloading; if no, press ESC to cancel the current operation. **Be cautioned that parameter uploading and downloading between two inverters with incompatible parameters are likely to cause operation failure of the inverters.**

4.4 Run/Stop

After setting the parameters, press the RUN key **RUN** to enable the normal operation of the inverter, and the STOP key **STOP** to stop the inverter. The M.K **M.K** can be defined to free parking or to stopping inverter operation by changing the function code F12.00 to 5.

When function code F01.34 is set to corresponding self-learning mode, it is required to press RUN **RUN** so that the inverter can enter corresponding parameter identification status; upon parameter identification, it will show "TUNE"; when identification is done, it will return to the original display, and the function code F01.34 will automatically change to 0. Upon rotation parameter identification by the inverter, the motor may rotate; in emergent cases, the user may press STOP **STOP** to cancel identification.

Chapter 5 Trial Run

5.1 Inverter Commissioning Process

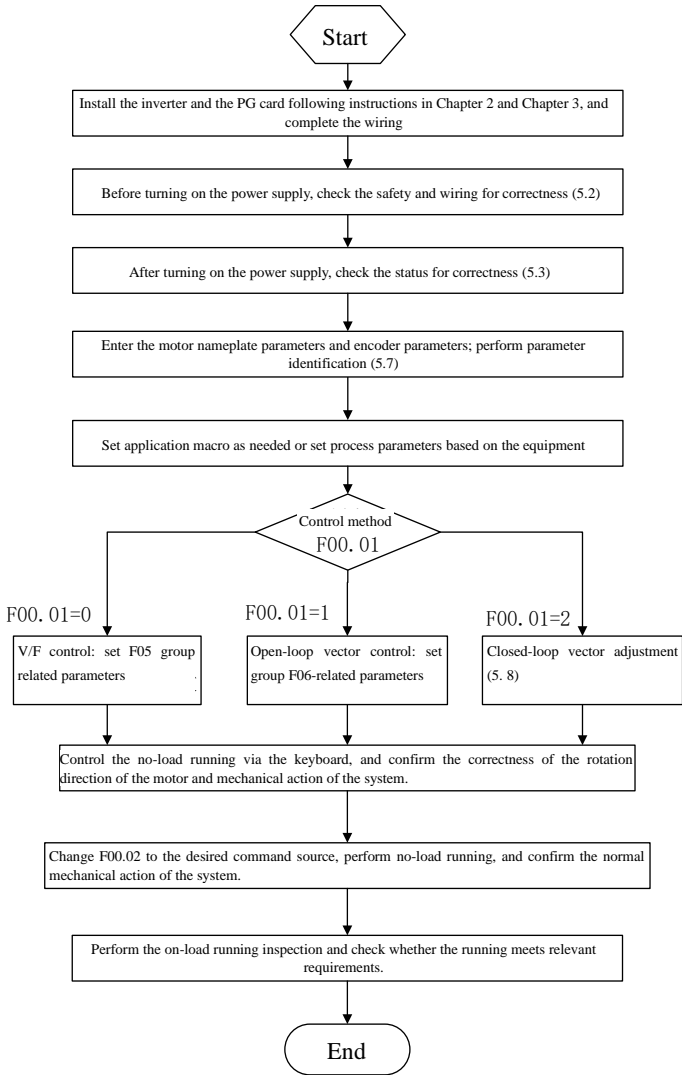

Fig. 5-1 Inverter Commissioning Flowchart

5.2 Confirmation before Power-on

Please confirm the following items before turning on the power supply:

Item to be confirmed	Confirmation content
Power wiring confirmation	Check whether the input power voltage is consistent with the voltage of the inverter.
	Confirm that the circuit breaker has been connected to the power supply circuit, and the power cables are correctly connected to the input terminals (R, S, T) of the inverter.
	Make sure that the inverter and motor are properly grounded.
Motor wiring confirmation	Confirm that the motor is correctly connected to the output terminals (U, V, W) of the inverter, and the motor wiring is secured.
Confirmation of braking unit and braking resistor	Make sure that the braking resistor and braking unit are properly connected (use the dynamic braking resistor if necessary during operation).
Control terminal wiring confirmation	Check whether the control terminals of the inverter are correctly and reliably connected to other controls.
Control terminal status confirmation	Make sure that the control terminal circuit of the inverter is disconnected to prevent operation upon powering on.
Check wiring of the PG card and the encoder	When closed-loop control is required, it is required to check wiring of the PG card and the encoder for correctness and reliability
Mechanical load confirmation	Confirm that the machinery is in the no-load state and free of danger in operation.

5.3 Inverter Status Confirmation after Power-on

After the power supply is turned on, the control panel (keyboard) of the inverter displays the following information in the normal status.

Status	Display	Note
During normal operation	The output frequency is 0 and the given frequency is 0	The digital setting 0Hz is displayed by default
Protection	Protection code in character or Exx format	The protection code is displayed in the protection status. See the protection measures in Chapter 6.

5.4 Precautions for Application Macro Setting

F16.00 is an industry application macro option. Select the application macro according to the specific application, and press the Enter key to automatically restore default settings.

Note: Select the application macro first, and then set the process parameters.

5.5 Start and Stop Control

F00.02=0: keyboard control

The start and stop of the inverter are controlled by the RUN key, STOP key on the keyboard. In the case of no trip protection, press the RUN key to enter the running status. If the strip LED indicator above the RUN key is

solidly ON, it indicates that the inverter is in the running state. If it flickers, it means that the inverter is decelerating to stop.

F00.02=1: terminal control

The inverter start and stop are controlled by the start and stop control terminals defined by the function code F02.00 to F02.06. Terminal control is dependent on F00.03.

F00.02=2: communication control

The inverter start and stop are controlled by the host through the RS485 communication port.

F04.00=0: direct start

The inverter is started at the starting frequency, following the DC braking (not suitable when F04.04=0) and pre-excitation (not suitable when F04.07=0). The starting frequency will change to the set frequency after the holding time.

F04.00=1: start with speed tracking

The inverter is smoothly started at the current rotating frequency of the motor, following the speed tracking.

F04.19=0: deceleration to stop

The motor decelerates to stop according to the deceleration time set in the system.

F04.19=1: free stop

When there is a valid stop command, the inverter will stop output immediately, and the motor will freely coast to stop. The stop time depends on the inertia of the motor and load.

Function code	Function code name	Parameter description	Default setting	Attribute
F00.03	Options of terminal control mode	0: terminal RUN (running) and F/R (forward/reverse) 1: terminal RUN (forward) and F/R (reverse) 2: terminal RUN (forward), Xi (stop) and F/R (reverse) 3: terminal RUN (running), Xi (stop) and F/R (forward/reverse)	0	○

Terminal RUN: Xi terminal is set to “1: terminal RUN”

Terminal F/R: Xi terminal is set to “2: running direction F/R”

Terminal control can be divided into two types: two-line control and three-line control.

Two-line control:

F00.03=0: the terminal RUN is enabled and the terminal F/R controls forward/reverse running.

The terminal RUN is activated/deactivated to control the start and stop of the inverter; terminal F/R is activated/deactivated to control the forward/reverse running. The logic diagram is shown in Fig. 5-2 (B);

F00.03=1: the terminal RUN controls forward running, and the terminal F/R is in the reverse mode.

Enable/Disable the terminal RUN to control the forward running and stop of the inverter, and the terminal

F/R to control the reverse running and stop. When the terminals RUN and F/R are enabled simultaneously, the inverter will be stopped. When the mode of deceleration to stop is selected, the logic of forward/reverse running is as shown in Fig. 5-2 (d);

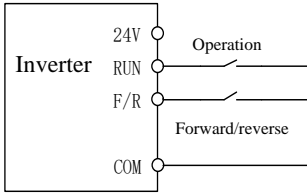

(a) Wiring diagram of two-line control (F00.03=0)

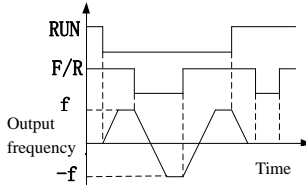

(b) F04.09=0, F00.03=0, run the forward/reverse logic

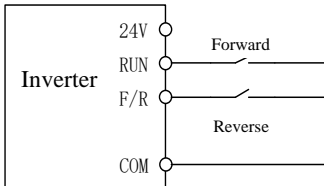

(c) Wiring diagram of two-line control (F00.03=1)

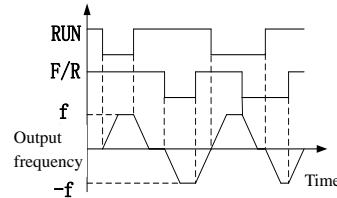

(b) F04.19=0, F00.03=1, run the forward/reverse logic

Fig. 5-2 Two-line Control

Three-line control:

F00.03=2: the terminal RUN controls forward running, the terminal Xi is for stop, and the terminal F/R is in the reverse status.

The terminal RUN is normally ON for forward running, and the terminal F/R is normally ON for reverse running, with valid pulse edges. The terminal Xi is normally closed for stop, with the valid level. When the inverter is in the running status, press Xi to stop it. When the parking mode is F04.19=0, the logic of deceleration to stop is shown in Fig. 5-3 (b). Xi is the terminal among X1~X7 that is defined by F02.00~F02.06 for “three-line running and stop control”;

Note: X7 is high-speed pulse input; the supported frequency is 200kHz.

F00.03=3: the terminal RUN is for running, Xi for stop and F/R for forward/reverse control.

The terminal RUN is normally ON for running, with the valid pulse edge, F/R for forward/reverse switching (forward in the OFF status and reverse in the ON status), and Xi is normally OFF for stop, with the valid level. In the case of deceleration to stop (F04.19=0), the logic diagram is as shown in Fig. 5-3(d).

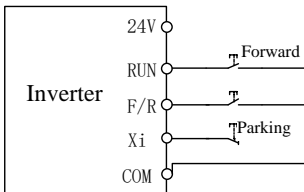

(a) Wiring diagram of three-line control (F00.03=2)

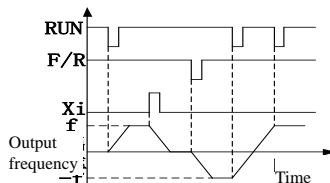

(b) F04.19=0, F00.03=2: forward/reverse running logic

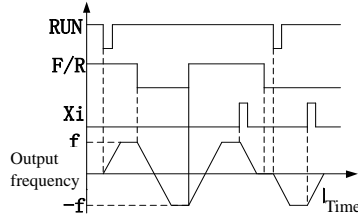
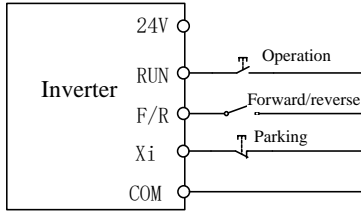

(a) Wiring diagram of three-line control (F00.03=3)

(d) F04.19=0, F00.03=3: forward/reverse running logic

Fig. 5-3 Three-line Control

5.6 Common Process Parameters of Inverter

Function code	Function code name	Parameter description	Unit	Default setting	Attribute
F00.01	Drive control mode of motor 1	0: V/F control (VVF) 1: Speed sensorless vector control (SVC) 2: Speed sensor vector control (FVC)		0	○
F00.04	Options of main frequency source A	0: digital frequency setting F00.07 1: AI1 2: AI2 3: AI3 4: AI4 (expansion card) 5: high frequency pulse input (X7) 6: Percentage setting of main frequency communication 7: Direct setting of main frequency communication 8: digital potentiometer setting		0	○
F00.07	Digital frequency setting	0.00 to maximum frequency F00.16	Hz	0.00	●
F00.14	Acceleration time 1	0.00~650.00 (F15.13=0)	s	15.00	●
F00.15	Deceleration time 1	0.00~650.00 (F15.13=0)	s	15.00	●
F00.16	Maximum frequency	1.00~600.00	Hz	50.00	○
F00.18	Upper frequency limit	Lower frequency limit F00.19 to maximum frequency F00.16	Hz	50.00	●
F00.19	Lower frequency limit	0.00 to upper frequency limit F00.18	Hz	0.00	●
F00.21	Reverse control	0: Allow forward/reverse running 1: Prohibit reversing		0	○

Note: Common process parameters may also include the input and output terminal function settings. Refer to the F02 and F03 groups in the function table.

5.7 Motor Parameter Identification

For the better control performance, motor parameters must be identified.

Identification Method	Application	Identification Effect
F01.34=1 Static self-learning of asynchronous motor	It is applied where the motor and load cannot be separated easily and rotary self-learning is not allowed.	General
F01.34=11		

Static self-learning of synchronous motor		
F01.34=2 Rotary self-learning of asynchronous motor	Scenarios where the motor and load can be separated easily and open-loop control is adopted. Before operation, the motor shaft should be separated from the load. The motor under load must not be put into rotary self-learning.	Good
F01.34=12 Rotary self-learning of synchronous motor		
F01.34=3 Self-learning of asynchronous motor encoder	Closed-loop control; scenarios where the motor and load can be separated easily and closed-loop control is adopted. (For a synchronous motor with an encoder, encoder self-learning is required)	Optimal
F01.34=13 encoder self-learning of synchronous motor		

- Prior to self-identification, make sure that the motor is stopped; otherwise, self-identification cannot be performed properly.

Parameter identification steps

- Where the motor and load can be separated, the mechanical load and motor should be completely separated in the power-off status.
- After the power-on, set the command source of the inverter to keyboard control (F00.02=0).
- Enter the nameplate parameters of the motor accurately.

Motor	Corresponding Parameter	
Motor 1 (Motor 2 corresponds to parameters of group F14)	F01.00 Motor type	F01.01 Rated power of electric motor
	F01.02 Rated voltage of motor	F01.03 Rated current of motor
	F01.04 Rated frequency of motor	F01.05 Rated speed
	F01.06: Motor winding connection	

- For the asynchronous motor:
 - Set F01.34=1 for confirmation and press the RUN key. The inverter will start the static self-identification of the motor.
 - Set F01.34=2, make confirmation and press the RUN key. The inverter will start rotation self-identification of the motor.
 - Set F01.34=3, make confirmation and press the RUN key. The inverter will start encoder self-identification of the motor and encoder.
- For the synchronous motor:
 - Set F01.34=11, make confirmation and press the RUN key. The inverter will start stillness self-identification of the motor.
 - Set F01.34=12, make confirmation and press the RUN key. The inverter will start rotation self-identification of the motor.
 - Set F01.34=13, make confirmation and press the RUN key. The inverter will start encoder self-identification of the motor and encoder.
- It takes about two minutes to complete the self-identification of the motor. Then the system will return to the initial power-on status from the “tune” interface.
- If multiple motors are used in parallel, the rated power and rated current input of the motors should be the sum of power and current of these motors.

If two motors are used alternately, the parameters of the motor 2 in the F14 group need to be set separately, and identified based on F14.34.

5.8 Closed-loop vector adjustment procedures

- Set the command source of the inverter to keyboard control and the main frequency source to digital frequency F00.07 (5.00Hz); set F12.00 M.K multi-functional key to option: 3 (Forward/Reverse switching); drive control mode of motor F00.01: 0 (VVF).
- Press "RUN" on the keyboard to run the inverter; check F18.02 (PG feedback frequency) - it should fluctuate around 5.00Hz after stabilization; then press M.K to make the inverter run reversely, and after stabilization the feedback frequency should fluctuate around -5.00Hz. Afterwards, set F00.07 to 10.00Hz, 25.00Hz and 50.00Hz successively (make sure it is safe and technologically allowed!) Repeat the above operations. If all goes normal, it means the PG card and encoder are properly wired and set.
- If the motor rotation direction is opposite to the actual direction, please exchange connection of any motor line pair; if the feedback frequency direction of the encoder is opposite to the actual direction (F18.02 and F18.01 are opposite in direction), please exchange the wiring connection of phase A and B on the PG card; if the feedback frequency value is incorrect, please check F01.25 encoder line count.

5.9 Abnormality handling

Abnormal rotating direction of the motor

- Check whether the parameter value of F00.03 is correctly set. The logic diagram is shown in Fig. 5-2 and Fig. 5.3.
- Check the motor wiring for correctness.
- Seek technical support.

Abnormal self-learning of encoder

- Check the motor wiring line count for correctness.
- Check all PG cards of the encoder for proper correspondence.
- Check the motor encoder wiring for correctness.
- Seek technical support.

Chapter 6 Solution

Protection content

When any abnormality occurs to the inverter, the digital keyboard display will show the corresponding protection code and parameters, the protection relay and protection output terminal will work, and the inverter will stop the output. In case of protection, the motor will stop rotating normally or slow down until it is stopped. The protection contents and solutions of the EM760 series inverter are shown in Table 6-1.

Table 6-1 Protection Contents and Solutions of EM760 Series Inverter

Protection code	Protection Type	Protection Cause	Protection Solution
E01	Short circuit protection	<ol style="list-style-type: none"> 1. Inter-phase short circuit 2. Short circuit of the external braking resistor. 3. The inverter module is damaged. 	<ol style="list-style-type: none"> 1. Check the wiring for short circuits. 2. Investigate the cause and reset the controller after implementing the corresponding solutions. 3. Seek technical support.
E02	Instantaneous overcurrent	<ol style="list-style-type: none"> 1. The acceleration and deceleration time is too short. 2. In the V/F drive mode, the V/F curve setting is unreasonable. 3. The motor is running during startup. 4. The motor used is beyond the capacity of the inverter or the load is too heavy. 5. Motor parameters are not suitable and need to be identified. 6. The phases on the output side of the inverter are short-circuited. 7. The inverter is damaged. 	<ol style="list-style-type: none"> 1. Increase the acceleration and deceleration time. 2. Reasonably set the V/F curve. 3. Enable speed tracking or start DC braking. 4. Use the appropriate motor or inverter. 5. Identify the motor parameters. 6. Check the wiring for short circuits. 7. Seek technical support.
E04	Steady-state overcurrent	The same as E02	The same as E02
E05	Overvoltage	<ol style="list-style-type: none"> 1. The deceleration time is too short, and the motor has too much regenerated energy. 2. The braking unit or braking resistor forms an open circuit. 3. The braking unit or braking resistor does not match. 4. The power voltage is too high. 	<ol style="list-style-type: none"> 1. Increase the deceleration time. 2. Check the wiring of the braking unit and braking resistor. 3. Use a suitable braking unit/braking resistor. 4. Reduce the power voltage to the specified range. 5. For the model of the built-in braking

		5. The energy consumption braking function is not enabled	unit, set F15.30 to 1, and enable the energy consumption braking.
E06	Undervoltage	<ol style="list-style-type: none"> 1. The input power supply is subject to phase loss. 2. The terminals of the input power supply are loose. 3. The voltage of the input power supply drops too much. 4. The switch contacts of the input power supply are aging. 	<ol style="list-style-type: none"> 1. Check the input power supply and wiring. 2. Tighten the screws of input terminals. 3. Check the air circuit breaker and contactor.
E07	Input phase loss	<ol style="list-style-type: none"> 1. The input power supply is subject to phase loss. 2. The input power supply fluctuates greatly. 	<ol style="list-style-type: none"> 1. Check the input power supply. 2. Check the wiring of the input power supply. 3. Check whether the terminal is loose 4. Use a voltage regulator on the input side.
E08	Output phase loss	<ol style="list-style-type: none"> 1. The output terminals U, V and W have phase losses. 	<ol style="list-style-type: none"> 1. Check the connection between the inverter and motor. 2. Check whether the output terminal is loose. 3. Check whether the motor winding is disconnected.
E09	Inverter overload	<ol style="list-style-type: none"> 1. The acceleration and deceleration time is too short. 2. In the V/F drive mode, the V/F curve setting is unreasonable. 3. The load is too heavy. 4. The braking time is too long, the braking intensity is too high, or DC braking is enabled repeatedly. 	<ol style="list-style-type: none"> 1. Increase the acceleration and deceleration time. 2. Reasonably set the V/F curve. 3. Use the inverter that matches the load. 4. Reduce the braking time and braking intensity. Do not enable DC braking repeatedly.
E10	Inverter overheat	<ol style="list-style-type: none"> 1. The ambient temperature is too high. 2. The inverter is subject to poor ventilation. 3. The cooling fan fails. 	<ol style="list-style-type: none"> 1. The operating environment of the inverter should meet the specifications. 2. Improve the ventilation environment and check whether the air duct is blocked. 3. Replace the cooling fan.
E11	Parameter setting conflict	<ol style="list-style-type: none"> 1. There is a logic conflict in parameter settings. 	<ol style="list-style-type: none"> 1. Check whether parameters set is illogical before the protection.
E12	Motor overheat	<ol style="list-style-type: none"> 1. The temperature measured by the motor temperature sensor is greater than the set threshold. 2. The motor temperature sensor is disconnected. 	<ol style="list-style-type: none"> 1. Check whether the thermal protection threshold of the motor is appropriate. 2. Check whether the sensor is disconnected.

		<ol style="list-style-type: none"> 3. Excess environment temperature. 4. The load is too heavy. 	<ol style="list-style-type: none"> 3. Strengthen the heat dissipation of the motor. 4. The motor model is not suitable.
E13	Motor overload	<ol style="list-style-type: none"> 1.The acceleration and deceleration time is too short. 2. In the V/F drive mode, the V/F curve setting is unreasonable. 3. The load is too heavy. 	<ol style="list-style-type: none"> 1. Increase the acceleration and deceleration time. 2. Reasonably set the V/F curve. 3. Use a motor matching the load.
E14	External protection	<ol style="list-style-type: none"> 1. The protection terminal of the external device acts. 	<ol style="list-style-type: none"> 1. Check the external device.
E15	Inverter memory protection	<ol style="list-style-type: none"> 1.Interference results in memory reading and writing errors. 2. The internal memory of the controller is read and written repeatedly, causing damage to the memory. 	<ol style="list-style-type: none"> 1. Press the STOP key for resetting and retry. 2. For the parameters (e.g. frequency setting) to be modified frequently, set F10.56 to 11 after debugging.
E16	Communication error	<ol style="list-style-type: none"> 1. Communication timeout is enabled in the discontinuous communication system. 2. Communication is disconnected. 	<ol style="list-style-type: none"> 1. F10.03 is set to 0.0 in the discontinuous communication system. 2. Adjust the F10.03 communication timeout. 3. Check whether the communication cable is disconnected.
E17	Abnormality of inverter temperature sensor	The inverter temperature sensor is disconnected or short-circuited.	<ol style="list-style-type: none"> 1. Seek technical support.
E18	The soft start relay is not engaged.	<ol style="list-style-type: none"> 1. The wiring gets loose. 2. The soft start relay fails. 	<p>Check the inverter wiring.</p> <ol style="list-style-type: none"> 1. Seek technical support.
E19	Error of current detection circuit	The detection circuit of the drive board or control board is damaged.	<ol style="list-style-type: none"> 1. Seek technical support.
E20	Stall protection	<ol style="list-style-type: none"> 1. The deceleration time is too short. 2. Error of dynamic brake for deceleration. 3. The load is too heavy. 	<ol style="list-style-type: none"> 1. Increase the deceleration time. 2. Check the dynamic brake. 3. Check whether the motor cannot be stopped as it is driven by another load.
E21	PID feedback disconnection	<ol style="list-style-type: none"> 1. The PID feedback is greater than the upper limit (F09.24) or less than the lower limit (F09.25), depending on the type of the feedback sensor. 	<ol style="list-style-type: none"> 1. Check whether the feedback line falls off. 2. Check whether the sensor is working abnormally. 3. Adjust the detection value of feedback disconnection to a reasonable level.
E22	Encoder fault	<ol style="list-style-type: none"> 1. The encoder is not properly wired. 2. The PG card is not installed properly. 	<ol style="list-style-type: none"> 1. Check the wiring of the PG card and encoder. 2. Check whether the PG card is inserted properly.

		<ol style="list-style-type: none"> The PG card selected is not of the right type. The encoder is damaged. There is on-site interference. 	<ol style="list-style-type: none"> Check the PG card type selected. Replace the encoder. Take electromagnetic compatibility measures (e.g. use of magnetic ring) for the inverter output cable.
E23	Keyboard memory fails	<ol style="list-style-type: none"> Interference results in memory reading and writing errors. The memory is damaged. 	<ol style="list-style-type: none"> Press the STOP key for resetting and retry. Seek technical support.
E24	Self-identification error – Auto tuning error	<ol style="list-style-type: none"> Press the STOP key during parameter identification auto-tuning. The external terminal stops working (FRS = ON) properly during parameter identification auto-tuning. The motor is not connected. The rotary self-learning auto-tuning motor is not disconnected from the load. The motor fails. 	<ol style="list-style-type: none"> Press the STOP key for resetting. The external terminal should not be operated during parameter identification auto-tuning. Check the connection between the inverter and motor. Disconnect the rotary self-learning auto-tuning motor from the load. Check the motor.
E25	Motor overspeed protection	<ol style="list-style-type: none"> PG card is not connected Encoder line count F01.25 is not properly set AB phase sequence F01.27 is incorrect Excessive load results in greater motor speed than the given inverter speed or reverse rotation of the motor 	<ol style="list-style-type: none"> Connect the PG card or switch to V/F control Set the encoder line count according to the encoder instructions Exchange the A and B phase wiring of the encoder. Reduce the load or replace with an inverter and motor of the immediately greater power.
E26	Load loss protection	<ol style="list-style-type: none"> The motor is not connected or does not match the load. Load loss occurs. The parameters of load loss protection are not set reasonably. 	<ol style="list-style-type: none"> Check the wiring and use the appropriate motor Check the equipment. Change the off-load detection level F07.22 and detection time F07.23.
E27	Up to cumulative power-on time	<ol style="list-style-type: none"> The inverter maintenance time is up. 	<ol style="list-style-type: none"> Please contact the dealer for technical support.
E28	Up to cumulative running time	<ol style="list-style-type: none"> The inverter maintenance time is up. 	<ol style="list-style-type: none"> Please contact the dealer for technical support.
E43	Material protection cutoff	<ol style="list-style-type: none"> When the external signal is detected, the external signal terminal is closed. During automatic detection, the feedback is greater than the upper voltage limit or less than the 	<ol style="list-style-type: none"> When disconnection occurs upon startup, reduce the initial feedforward and the soft start feedforward gain. When oscillation disconnection occurs during operation, change the proportion P.

		lower voltage limit.	3. Check whether it is caused by loose connection of the sensor.
E44	Wiring protection	1. The valid time of the wiring detection terminal is too long. 2. The invalid time of the wiring detection terminal is too long.	1. Check whether the sensor can work normally. 2. Check whether the terminal is capable of properly judging the closing and opening.
E57	Overpressure in pipeline network	1. The feedback pressure in the water supply application is too high.	1. Check whether the sensor is in the abnormal status. 2. Check whether the analog input terminal can be normal. 3. Check the external device.
E76	The output is short-circuited to ground.	1. The output is short-circuited to ground. 2. The inverter module is damaged.	1. Check whether the output cable sheath is damaged and whether the motor shell is broken down. 2. Investigate the cause and reset the controller after implementing the corresponding solutions. 3. Seek technical support.
E81	Encoder line ppr count fault	1. An incorrect encoder line ppr count is set. 2. The motor encoder is improperly wired	1. Check the motor wiring line count for correctness. Check if the encoder ppr no. is correct. 2. Check the motor encoder wiring for correctness.
C30	No PG card is detected	1. F00.01 is set to 2, but no PG card is inserted	1. When closed-loop control is used, please insert corresponding encoder PG card
C31	Two absolutely identical cards	1. Two absolutely identical cards are inserted in the card slots	1. Please check whether a wrong card is inserted
C32	Two cards of the same type	1. Two cards of the same type are inserted in the card slots; for example, both are PG cards or communication cards	1. Please check whether a wrong card is inserted

Chapter 7 Maintenance

Daily Maintenance of Inverter

Due to the operating environment, aging of internal components and other factors, the inverter may have various faults. Thus, the inverter must be regularly maintained during storage and use.

- Before use, check if the inverter has intact external conditions and screws are tight after transportation.
- During the normal operation of the inverter, clean dust on a regular basis and check whether the screws are tightened.
- If the inverter is not in use for a long time, it is recommended to power it on (preferably 30 min) once every six months during storage, to prevent the failure of electronic components.
- The inverter should not be used in a place that exposes it to dampness, vibration, oily dirt and conductive dust. When the inverter needs to operate in such a place, it must be set in an electrical cabinet or cabin with protective measures.

Please check the following items during the normal operation of the inverter:

- Check the motor for abnormal noise, vibration and abnormal heating.
- Check whether the ambient temperature is too high.
- Check whether the output current is normal.
- Check whether the cooling fan of the inverter works properly.

Depending on the usage, the user needs to check the inverter on a regular basis to eliminate faults and safety hazards. For inspection, it is required to turn off the power supply; do not perform the inspection until the lapse of 10 minutes after the keyboard LED goes off. The check content is shown in Table 7-1.

Table 7-1 Content of regular inspection

Check Item	Check Content	Solution
Main circuit terminal	Check whether the screws are loose.	Tighten the screws with a screwdriver.
Heat sink and vent		
PCB (printed circuit board)	Check them for dust, foreign matters and clogging.	Purge them with dry compressed air (pressure: 4-6 kg/cm ²).
Cooling fan	Check it for abnormal noise and vibration. Check whether the cumulative running time is up to 20,000 hours.	Replace the cooling fan
Electrolytic capacitor	Check it for color changes, odor and bubbles.	Replace the electrolytic capacitor.

In order to make the inverter work properly in a long time, regular maintenance and replacement must be performed regularly based on the service life of its internal components. The service life of the components of the inverter varies depending on the operating environment and conditions.

Table 7-2 Replacement Intervals of Inverter Components

Name of Part	Standard Replacement Interval (Year)
Cooling fan	2-3 years
Electrolytic capacitor	4-5 years

The operating conditions for replacement of the inverter components listed in the above table are as follows:

Ambient temperature: 40°C

Load factor: Less than 80%.

Operating time: less than 12 hours per day.

Instructions for Inverter Warranty

Our company will provide warranty services for the inverter in the following cases.

The warranty applies to the inverter body only. The warranty covers failure and damage of the inverter within twelve months' operation. Any fault or damage beyond the warranty period may be eliminated by the company at a proper cost. Failure or damage the inverter is not covered by the warranty during the one-year warranty period in any of the following cases:

- The inverter is damaged due to noncompliance with the instructions in this manual during operation;
- The inverter is damaged due to flood, fire, abnormal voltage, etc.;

- The inverter is damaged as a result of incorrect wiring;
- The inverter is damaged due to unauthorized modification.
- The warranty does not cover any damage caused to the inverter by severe environmental conditions, particularly by exposure to conductive dust, salt spray, corrosive gas, condensation, oily dirt and obvious vibration.

Relevant service costs are calculated based on the actual amount, and the principles in the separate agreement will prevail.

Chapter 8 Select Accessories

8.1 Braking Resistor

When the braking performance does not meet the customer requirement, it is required to connect an external braking unit and braking resistor to realize timely release of energy.

The power of the braking resistor can be calculated by the following formula:

Resistor power P_b = inverter power P × braking frequency D

D - Braking frequency. This is an estimated value, depending on the load conditions. Under normal circumstances, D is as follows:

D=10% under ordinary loads

D=5% for occasional braking loads

D = 10% to 15% for elevators

D = 5% to 20% for centrifuges

D = 10% to 20% for oilfield kowtow machines

D = 50% to 60% for unwinding and winding. It should be calculated based on the system design indicators.

D = 50% to 60% for lifting equipment with a lowering height over 100m

The recommended power and resistance for the braking resistor of the EM760 series inverter are given in the table below. The recommended resistor power is calculated based on the braking rate (10% to 20%). It is for reference only. If the inverter is used in the case of frequent acceleration/deceleration or continuous braking, the power of the braking resistor needs to be increased. The user can change the value according to the load conditions, but within the specified range.

Inverter Model	Motor (kW)	Resistance (Ω)	Resistor Power (W)	Wire (mm ²) Connected to Resistor
EM760-0R7G/1R5P-3B	0.75/1.5	≥ 360	≥ 200	1
EM760-1R5G/2R2P-3B	1.5/2.2	≥ 180	≥ 400	1.5
EM760-2R2R/3R0P-3B	2.2/3.0	≥ 180	≥ 400	1.5
EM760-4R0G/5R5P-3B	4/5.5	≥ 90	≥ 800	2.5
EM760-5R5G/7R5P-3B	5.5/7.5	≥ 60	≥ 1000	4
EM760-7R5G/9R0P-3B	7.5/9.0	≥ 60	≥ 1000	4
EM760-011G/015P-3B	11/15	≥ 30	≥ 2000	6
EM760-015G/018P-3B	15/18	≥ 30	≥ 2000	6
EM760-018G/022P-3B	18.5/22	≥ 30	≥ 2000	6
EM760-022G/030P-3B	22/30	≥ 15	≥ 4000	6
EM760-030G/037P-3B	30/37	≥ 15	≥ 4000	6
EM760-037G/045P-3B	37/45	≥ 10	≥ 6000	6
EM760-045G/055P-3B	45/55	≥ 10	≥ 6000	6
EM760-055G/075P-3B	55/75	≥ 7.5	≥ 8000	6
EM760-075G/090P-3B	75/90	≥ 6	≥ 8000	6

The wires listed above refer to the outgoing wires of a single resistor. If resistors are connected in parallel, the bus should be enlarged accordingly. The withstand voltage of the wires should be AC300V or above for the single-phase model and AC450V or above for the three-phase model. Cables should be resistant to 105°C.

8.2 Braking unit

EM760 inverters of 22kW or above and without built-in braking units need to be optionally equipped with our BR100 braking units (power range: 45-315kW). The models of our braking units are as follows.

Model and specification	Application	Minimum Resistance (Ω)	Average Braking Current I_{av} (A)	Peak Current I_{max} (A)	Applicable Inverter Power (kW)
BR100-045	Energy	10	45	75	18.5~45

	consumption braking				
BR100-160	Energy consumption braking	6	75	150	55~160
BR100-200	Energy consumption braking	5	100	200	160~200
BR100-315	Energy consumption braking	3	120	300	185~315
BR100-400	Energy consumption braking	3	200	400	315~400

★ When BR100 works with the minimum resistance, the braking unit can work continuously at the braking frequency $D=33\%$.

In the case of $D>33\%$, the braking unit will work intermittently. Otherwise, an over-temperature protection fault will occur.

8.2.1 Selection of Connecting Wires

Since all braking units and braking resistors work at high voltage ($>400\text{VDC}$) and in the discontinuous mode, please select appropriate wires.

Specification and model	Average Braking Current $I_{av}(A)$	Peak Braking Current $I_{max}(A)$	Cross-section (mm ²) of Copper-core Cable
BR100-045	45	75	10
BR100-160	75	150	16
BR100-200	100	200	25
BR100-315	120	300	25
BR100-400	200	400	35

Flexible cables have higher flexibility. Because cables may be in contact with high-temperature devices, it is recommended to use copper-core and heat-resistant flexible cables or flame-retardant cables. The braking unit should be as close to the inverter and braking resistor as possible with the maximum distance of preferably no more than 2m. Otherwise, the DC-side cables should be twisted and used with magnetic rings to reduce radiation and inductance.

8.3 Option card

I/O expansion card

Specification and model	Note	Terminal Function
EM760-IO-A1	I/O expansion card	3-channel multi-functional digital signal input: X8~X10 2-channel relay output: The function of R3 is set by using function code F03.32; the function of R4 is set by using function code F03.33 2-channel analog signal input: 1-channel I4, supporting $-10\text{V}\sim+10\text{V}$ or $0\sim+10\text{V}$ voltage input 1-channel multi-functional digital signal input, supporting PT100/PT1000/PTC/KTY84

Expansion card for communication card

Specification and model	Note	Communication rate
EM760-CM-C1	CANopen communication	125kbps, 250kbps, 500kbps, 1Mbps

	card	
EM760-CM-PN1	PROFINET communication card	Support 100Mbps full duplex

Encoder expansion card (PG card)

For EM760 inverters, there are multiple types of general PG cards available for the user to choose according to the encoder output mode, as shown in the following table:

Specification and model	Item	Encoder type supported
EM760-PG-0D1	Open collector/differential PG card	It can be used in combination with a differential (line drive) output encoder, an open collector (OC) output encoder and a push-pull complementary output encoder. The maximum output is 100kHz. The output voltage can be 5V or alternatively 12V (optional by dial-up, 5V by default)
EM760-PG-0D2	Open-collector/differential PG card, with frequency dividing output	It can be used in combination with a differential (line drive) output encoder, an open collector (OC) output encoder, push-pull complementary output encoder, with frequency dividing output and NPN open collector output. The maximum input is 300kHz. The output voltage can be 5V or alternatively 12V (5V by default)
EM760-PG-U1	UVW differential PG card	UVW differential output encoder
EM760-PG-R1	Rotary transformer PG card	Rotary transformer output encoder
EM760-PG-S1	SinCos PG card	SinCos output encoder

Chapter 9 Function Code Table

Description of Function Code Table

The EM760 inverters have 22 groups of function codes (hereinafter referred to as “function codes”) as shown in the following table, and each group consists of several function codes. Among them, the F18 group is a monitoring parameter group used to view the inverter status; the F19 group is a fault record group used to view the details of the last three faults; and other groups are parameter setting groups to meet different functional requirements.

F00	Basic function parameter group	F01	Parameter group of motor 1
F02	Input terminal function group	F03	Output terminal function group
F04	Start/stop control parameter group	F05	V/F control parameter group
F06	Vector control parameter group	F07	Protection function setting group
F08	Multi-segment speed and simple PLC	F09	PID function group
F10	Communication function group	F11	User-selected parameter group
F12	Keyboard and display function group	F13	Torque control parameter group
F14	Parameter group of motor 2	F15	Auxiliary function group
F16	Customization function group	F17	Virtual I/O function group
F18	Monitoring parameter group	F19	Fault record group
F21	Special functional parameter groups of the winding machine	F45	Modbus free mapping parameter group

★: Some parameters of the current series are reserved, and their readings are 0. Some options of parameters are reserved and settable, but this may result in abnormal operation of the inverter. Please avoid misuse of such parameters.

★ Parameter properties: ●: Parameters that can be changed in any state; ○: Parameters that cannot be changed in the operating state; ×: Read-only parameters.

Table of functional parameters

Function code	Function code name	Parameter description	Unit	Default setting	Attribute
F00	Basic function parameter group				
F00.01	Drive control mode of motor 1	0: V/F control (VVF) 1: Speed sensorless vector control (SVC) 2: Speed sensor vector control (FVC)		0	○
F00.02	Options of command source	0: keyboard control (LOC/REM indicator ON) 1: terminal control (LOC/REM indicator: OFF) 2: communication control (LOC/REM indicator: flicker)		0	○
F00.03	Options of terminal control mode	0: terminal RUN (running) and F/R (forward/reverse) 1: terminal RUN (forward) and F/R (reverse) 2: terminal RUN (forward), Xi (stop) and F/R (reverse) 3: terminal RUN (running), Xi (stop) and F/R (forward/reverse)		0	○

User's Guide for EM760 series high-performance vector inverter

F00.04	Options of main frequency source A	0: digital frequency setting F00.07 1: AI1 2: AI2 3: AI3 4: AI4 (expansion card) 5: high frequency pulse input (X7) 6: main frequency communication setting (percentage) 7: main frequency communication setting (direct frequency)		0	○
F00.05	Options of auxiliary frequency source B	0: digital frequency setting F00.07 1: AI1 2: AI2 3: AI3 4: AI4 (expansion card) 5: high frequency pulse input (X7) 6: auxiliary frequency communication setting (percentage) 7: auxiliary frequency communication setting (direct frequency) 10: process PID 11: simple PLC		0	○
F00.06	Options of frequency source	0: main frequency source A 1: auxiliary frequency source B 2: main and auxiliary operation results 3: switching between main frequency source A and auxiliary frequency source B 4: switching between main frequency source A and main and auxiliary operation results 5: switching between auxiliary frequency source B and main and auxiliary operation results 6: Auxiliary frequency source B + feedforward calculation (winding application)		0	○
F00.07	Digital frequency setting	0.00 to maximum frequency F00.16	Hz	50.00	●
F00.08	Options of main and auxiliary operation	0: main frequency source A + auxiliary frequency source B 1: main frequency source A - auxiliary frequency source B 2: larger value of main and auxiliary frequency sources 3: smaller value of main and auxiliary frequency sources 4: main frequency source A - auxiliary frequency source B 5: main frequency source A + auxiliary frequency source B		0	○

User's Guide for EM760 series high-performance vector inverter

F00.09	Reference options of auxiliary frequency source B in main and auxiliary operation	0: relative to the maximum frequency 1: Relative to main frequency source A		0	○
F00.10	Gain of main frequency source	0.0~300.0	%	100.0	●
F00.11	Gain of auxiliary frequency source	0.0~300.0	%	100.0	●
F00.12	Synthetic gain of main and auxiliary frequency sources	0.0~300.0	%	100.0	●
F00.13	Analog adjustment of synthetic frequency	0: synthetic frequency of main and auxiliary channels 1: AI1 * synthetic frequency of main and auxiliary channels 2: AI2 * synthetic frequency of main and auxiliary channels 3: AI3* synthetic frequency of main and auxiliary channels 4: AI4* synthetic frequency of main and auxiliary channels 5: High frequency pulse (PULSE) * synthetic frequency of main and auxiliary channels		0	○
F00.14	Acceleration time 1	0.00~650.00 (F15.13=0)	s	15.00	●
F00.15	Deceleration time 1	0.0~6500.0 (F15.13=1) 0~65000 (F15.13=2)	s	15.00	●
F00.16	Maximum frequency	1.00~600.00	Hz	50.00	○
F00.17	Options of upper frequency limit control	0: set by F00.18 1: AI1 2: AI2 3: AI3 4: AI4 (expansion card) 5: high frequency pulse input (X7) 6: Communication setting (percentage) 7: Communication setting (direct frequency)		0	○
F00.18	Upper frequency limit	Lower frequency limit F00.19 to maximum frequency F00.16	Hz	50.00	●
F00.19	Lower frequency limit	0.00 to upper frequency limit F00.18	Hz	0.00	●
F00.20	Running direction	0: consistent direction 1: opposite direction		0	●
F00.21	Reverse control	0: Allow forward/reverse running 1: Prohibit reversing		0	○
F00.22	Duration of forward and reverse dead zone	0.00~650.00	s	0.00	●
F00.23	Carrier frequency	1.0~16.0 (rated power of the inverter: less than 4kW)	kHz	2.0	●

User's Guide for EM760 series high-performance vector inverter

		1.0-10.0 (rated power of the inverter: 5.5-7.5kW) 1.0 - 8.0 (rated power of inverter 11 - 45kW) 1.0 - 4.0 (rated power of inverter 55 - 90kW) 1.0 - 3.0 (rated power of inverter 110 - 560kW)			
F00.24	Automatic adjustment of carrier frequency	0: Invalid 1: valid 1 2: valid 2		1	○
F00.25	Noise suppression of carrier frequency	0: Invalid 1: Noise suppression mode 1 of carrier frequency 2: Noise suppression mode 2 of carrier frequency		0	○
F00.26	Noise suppression width	1~20		1	●
F00.27	Noise suppression intensity	0-10: Noise suppression mode 1 of carrier frequency 0-4: Noise suppression mode 2 of carrier frequency		0	●
F00.28	Options of motor parameter group	0: parameter group of motor 1 1: parameter group of motor 2		0	○
F00.29	User password	0~65535		0	○
F00.30	Model selection	0: G type 1: P type		0	○
F00.31	Frequency resolution	0:0.01Hz 1: 0.1Hz (speed unit: 10rpm)		0	○
F00.32	Frequency point corresponding to the lower limit of carrier frequency	0.00~F0.33	Hz	20.00	○
F00.33	Frequency point corresponding to the upper limit of carrier frequency	10.00~150.00	HZ	50.00	○
F00.34	Lower limit of carrier frequency	1.0~F00.23	kHz	2.0	○
F00.35	380V inverter supply voltage selection	0: 380V 1: 440V		0	○
F00.36	Start/stop channel selection for communication control	0: Modbus 1: Profinet 2: EtherCAT		0	○
F00.37	Communication-specific channel selection	3: CANopen 10: All protocols are valid		0	○
F00.38	Parameter locking function selection	0: Locked for all command channels 1: Only the keyboard locked		0	○
F00.39	Single-brush and	0: Single-brush		0	○

User's Guide for EM760 series high-performance vector inverter

	double-brush PWM switch control	1: Double-brush 2: Automatic switch			
F01	Parameter group of motor 1				
F01.00	Motor type	0: ordinary asynchronous motor 1: variable-frequency asynchronous motor 2: permanent magnet synchronous motor		0	○
F01.01	Rated power of electric motor	0.10~650.00	kW	Depending on the motor type	○
F01.02	Rated voltage of motor	50~2000	V	Depending on the motor type	○
F01.03	Rated current of motor	0.01 to 600.00 (rated power of motor: ≤ 75 kW) 0.1 to 6000.0 (rated power of motor: > 75 kW)	A	Depending on the motor type	○
F01.04	Rated frequency of motor	0.01~600.00	Hz	Depending on the motor type	○
F01.05	Rated speed	1~60000	rpm	Depending on the motor type	○
F01.06	Motor winding connection	0: Y 1: Δ		Depending on the motor type	○
F01.07	Rated power factor of motor	0.600~1.000		Depending on the motor type	○
F01.08	Motor efficiency	30.0~100.0	%	Depending on the motor type	○
F01.09	Stator resistance of asynchronous motor	1-60000 (rated power of motor: ≤75kW) 0.1 to 6000.0 (rated power of motor: > 75 kW)	mΩ	Depending on the motor type	○
F01.10	Rotor resistance of asynchronous motor	1-60000 (rated power of motor: ≤75kW) 0.1 to 6000.0 (rated power of motor: > 75 kW)	mΩ	Depending on the motor type	○
F01.11	Leakage inductance of asynchronous motor	0.01 to 600.00 (rated power of motor: ≤ 75 kW) 0.001 to 60.000 (rated power of motor: > 75 kW)	mH	Depending on the motor type	○
F01.12	Mutual inductance of asynchronous motor	0.1 to 6000.0 (rated power of motor: ≤ 75 kW) 0.01 to 600.00 (rated power of motor: > 75 kW)	mH	Depending on the motor type	○
F01.13	No-load excitation current of asynchronous motor	0.01 to 600.00 (rated power of motor: ≤ 75 kW) 0.1 to 6000.0 (rated power of motor: > 75 kW)	A	Depending on the	○

User's Guide for EM760 series high-performance vector inverter

				motor type	
F01.14	Magnetic saturation coefficient 1 of asynchronous motor	10.00~100.00	%	87.00	○
F01.15	Magnetic saturation coefficient 2 of asynchronous motor	10.00~100.00	%	80.00	○
F01.16	Magnetic saturation coefficient 3 of asynchronous motor	10.00~100.00	%	75.00	○
F01.17	Magnetic saturation coefficient 4 of asynchronous motor	10.00~100.00	%	72.00	○
F01.18	Magnetic saturation coefficient 5 of asynchronous motor	10.00~100.00	%	70.00	○
F01.19	Stator resistance of synchronous motor	1-60000 (rated power of motor: ≤75kW) 0.1 to 6000.0 (rated power of motor: > 75 kW)	mΩ	Depending on the motor type	○
F01.20	d-axis inductance of synchronous motor	0.01 to 600.00 (rated power of motor: ≤ 75 kW) 0.001 to 60.000 (rated power of motor: > 75 kW)	mH	Depending on the motor type	○
F01.21	q-axis inductance of synchronous motor	0.01 to 600.00 (rated power of motor: ≤ 75 kW) 0.001 to 60.000 (rated power of motor: > 75 kW)	mH	Depending on the motor type	○
F01.22	Counter electromotive force of synchronous motor	10.0-2000.0 (counter electromotive force of rated speed)	V	Depending on the motor type	○
F01.24	Encoder type	0: ABZ gain encoder 3: SinCos encoder 1: UVW gain encoder 4: Rotary transformer		0	○
F01.25	Encoder line count	1~65535		1024	○
F01.26	Zero-pulse phase angle of encoder	0.0~359.9°		0.0	○
F01.27	AB pulse phase sequence	0: forward 1: reverse		0	○
F01.28	UVW encoder phase sequence	0: forward 1: reverse		0	○
F01.29	UVW initial offset phase angle	0.0~359.9°		0.0	○
F01.30	Pole pairs of rotary transformer	1~65535		1	○
F01.31	High-frequency filter coefficient of encoder	0-15		10	○

User's Guide for EM760 series high-performance vector inverter

F01.32	Detection time of speed feedback disconnection	0.0~10.0 (0.0: inactive detection of speed feedback disconnection)		1.0	○
F01.33	Speed feedback filtering time	0.000~0.100	s	0.002	○
F01.34	Motor parameter self-learning	0: No operation 1: static self-learning of asynchronous motor 2: rotation self-learning of asynchronous motor 3: Self-learning of asynchronous motor encoder 11: static self-learning of synchronous motor 12: rotary self-learning of synchronous motor 13: encoder self-learning of synchronous motor		0	○
F02	Input terminal function group				
F02.00	Options of X1 digital input function	0: no function 1: terminal running (RUN) 2: running direction (F/R) 3: stop control in three-line operation 4: forward jog (FJOG) 5: reverse jog (RJOG) 6: terminal UP 7: terminal DOWN 8: clear UP/DOWN offset 9: free stop 10: reset fault 11: multi-segment speed terminal 1 12: multi-segment speed terminal 2 13: multi-segment speed terminal 3 14: multi-segment speed terminal 4 15: multi-segment PID terminal 1 16: multi-segment PID terminal 2 17: multi-segment torque terminal 1 18: multi-segment torque terminal 2 19: acceleration and deceleration time terminal 1 20: acceleration and deceleration time terminal 2		1	○
F02.01	Options of X2 digital input function			2	○
F02.02	Options of X3 digital input function			11	○
F02.03	Options of X4 digital input function			12	○
F02.04	Options of X5 digital input function			13	○
F02.05	Options of X6 digital input function			14	○
F02.06	Options of X7 digital input function			10	○
F02.07	Options of AI1 digital input function			0	○
F02.08	Options of AI2 digital input function			0	○
F02.09	Options of AI3 digital input function			0	○
F02.10	Options of AI4 digital input function (expansion card)			0	○
F02.11	Options of X8 digital input function (expansion card)			0	○
F02.12	Options of X9 digital input function (expansion card)			0	○
F02.13	Options of X10 digital input function (expansion card)			0	○
F02.14	Reserved			0	×
	21: Acceleration and deceleration prohibition 22: operation pause 23: external fault input	34: counter input (≤250Hz) 35: high-speed count input (≤100kHz, only valid for X7) 36: count clearing		51: switching of main frequency source to digital frequency setting 52: switching of main	

User's Guide for EM760 series high-performance vector inverter

24: Switching of RUN command to keyboard 25: switching of RUN command to communication 26: Frequency source switching 27: clearing of regular running time 28: speed control/torque control switching 29: torque control prohibition 30: motor 1/motor 2 switching 31: resetting of simple PLC status (running from the first segment, with the running time cleared) 32: simple PLC time pause (keep running at current segment) 33: Zero-servo command		37: length counter input ($\leq 250\text{Hz}$) 38: High-speed length counting input ($\leq 100\text{kHz}$, only valid for X7) 39: length clearing 40: pulse input ($\leq 100\text{kHz}$, only valid for X7) 41: process PID pause 42: process PID integral pause 43: PID parameter switching 44: PID positive/negative switching 45: stop and DC braking 46: DC braking at stop 47: immediate DC braking 48: fastest deceleration to stop 50: external stop								frequency source to AI1 53: Switching of main frequency source to AI2 54: switching of main frequency source to AI3 55: Switching of main frequency source to high-frequency pulse input 56: switching of main frequency source to communication setting 57: inverter enabling 69: Reserving prohibited or 89: Reset feedforward 121: External material cutoff signal 122: Wiring detection signal 123: Brake reset terminal		
F02.15	Positive/negative logic 1 of digital input terminal	D7	D6	D5	D4	D3	D2	D1	D0		*0000000	○
		*	X7	X6	X5	X4	X3	X2	X1			
		0: positive logic is valid in the closed state/invalid in the open state 1: negative logic is valid in the closed state/invalid in the open state										
F02.16	Positive/negative logic 2 of digital input terminal	D7	D6	D5	D4	D3	D2	D1	D0		00000000	○
		X11	X10	X9	X8	A14	A13	A12	A11			
		0: positive logic is valid in the closed state/invalid in the open state 1: negative logic is valid in the closed state/invalid in the open state										
F02.17	Filtering times of digital input terminal	0-100; 0: no filtering; n: sampling every nms									2	○
F02.18	X1 valid delay time	0.000~650.00								s	0.000	●
F02.19	X1 invalid delay time	0.000~650.00								s	0.000	●
F02.20	X2 valid delay time	0.000~650.00								s	0.000	●
F02.21	X2 invalid delay time	0.000~650.00								s	0.000	●
F02.22	X3 valid delay time	0.000~650.00								s	0.000	●
F02.23	X3 invalid delay time	0.000~650.00								s	0.000	●
F02.24	X4 valid delay time	0.000~650.00								s	0.000	●
F02.25	X4 invalid delay time	0.000~650.00								s	0.000	●
F02.26	Minimum input pulse frequency	0.00 to maximum input pulse frequency F02.28								kHz	0.00	●
F02.27	Minimum input setting	-100.0~+100.0								%	0.0	●

User's Guide for EM760 series high-performance vector inverter

F02.28	Maximum input pulse frequency	0.01~100.00	kHz	50.00	●
F02.29	Maximum input setting	-100.0~+100.0	%	100.0	●
F02.30	Pulse input filtering time	0.00~10.00	s	0.10	●
F02.31	Options of analog input function	<p>Ones place: AI1 0: analog input 1: digital input (0 below 1V, 1 above 3V, the same as last time under 1-3V)</p> <p>Tens place: AI2; as above</p> <p>Hundreds place: AI3; as above</p> <p>Thousands place: AI4 (expansion card); as above</p>		0000D	○
F02.32	Options of analog input curve	<p>Ones place: Options of AI1 curve 0: curve 1 1: curve 2 2: curve 3 3: curve 4</p> <p>Tens place: AI2 curve selection; as above</p> <p>Hundreds place: AI3 curve selection; as above</p> <p>Thousands place: AI4 curve selection; as above</p>		3210D	○
F02.33	Minimum input of curve 1	0.00~F02.35	V	0.10	●
F02.34	Minimum input setting of curve 1	-100.0~+100.0	%	0.0	●
F02.35	Maximum input of curve 1	F02.33~10.00	V	9.90	●
F02.36	Maximum input setting of curve 1	-100.0~+100.0	%	100.0	●
F02.37	Minimum input of curve 2	-10.00~F02.39	V	0.10	●
F02.38	Minimum input setting of curve 2	-100.0~+100.0	%	0.0	●
F02.39	Maximum input of curve 2	F02.37~10.00	V	9.90	●
F02.40	Maximum input setting of curve 2	-100.0~+100.0	%	100.0	●
F02.41	Minimum input of curve 3	0.00V~F02.43	V	0.10	●
F02.42	Minimum input setting of curve 3	-100.0~+100.0	%	0.0	●
F02.43	Input of inflection point 1 of curve 3	F02.41~F02.45	V	2.50	●
F02.44	Input setting of inflection point 1 of curve 3	-100.0~+100.0	%	25.0	●
F02.45	Input of inflection point 2 of curve 3	F02.43~F02.47	V	7.50	●
F02.46	Input setting of inflection point 2 of curve 3	-100.0~+100.0	%	75.0	●

User's Guide for EM760 series high-performance vector inverter

F02.47	Maximum input of curve 3	F02.45~10.00	V	9.90	●
F02.48	Maximum input setting of curve 3	-100.0~+100.0	%	100.0	●
F02.49	Minimum input of curve 4	-10.00~F02.51	V	-9.90	●
F02.50	Minimum input setting of curve 4	-100.0~+100.0	%	-100.0	●
F02.51	Input of inflection point 1 of curve 4	F02.49~F02.53	V	-5.00	●
F02.52	Input setting of inflection point 1 of curve 4	-100.0~+100.0	%	-50.0	●
F02.53	Input of inflection point 2 of curve 4	F02.51~F02.55	V	5.00	●
F02.54	Input setting of inflection point 2 of curve 4	-100.0~+100.0	%	50.0	●
F02.55	Maximum input of curve 4	F02.53~10.00	V	9.90	●
F02.56	Maximum input setting of curve 4	-100.0~+100.0	%	100.0	●
F02.57	AI1 filtering time	0.000~10.000	s	0.100	●
F02.58	AI2 filtering time	0.000~10.000	s	0.100	●
F02.59	AI3 filtering time	0.000~10.000	s	0.100	●
F02.60	AI4 filtering time (expansion card)	0.000~10.000	s	0.100	●
F02.61	AD sampling hysteresis	2~50		2	○
F02.62	Selection of analog input AI1 type	0: 0~10V 3: -10~10V 4: 0~5V		0	○
F02.63	Selection of analog input AI2 type	0: 0~10V 1: 4~20mA 2: 0~20mA 4: 0~5V		1	○
F06.64	Analog input AI3 type selection	0: 0~10V 1: 4~20mA 2: 0~20mA 4: 0~5V		0	○
F02.65	Analog input AI4 type selection (expansion card)	0: 0~10V 2: retention 3: -10~10V 4: 0~5V		2	○
F03	Output terminal function group				
F03.00	Options of Y1 output function	0: no output 1: inverter running (RUN)		1	○
F03.01	Options of Y2 output function	2: up to output frequency (FAR) 3: output frequency detection FDT1		3	○
F03.02	Options of R1 output	4: output frequency detection FDT2		7	○

User's Guide for EM760 series high-performance vector inverter

	function (EA-EB-EC)	5: reverse running (REV)										
F03.03	Options of R2 output function (RA-RB-RC)	6: jog								8	○	
F03.04	Reserved	7: inverter fault								0	○	
	8: inverter ready to run 9: reach the upper frequency limit 10: reach the lower frequency limit 11: valid current limit 12: valid overvoltage stall 13: complete simple PLC cycle 14: reach the set count value 15: reach the specified count value 16: reach the length 17: motor overload pre-alarm 18: inverter overheat pre-alarm	19: reach the upper limit of PID feedback 20: reach the lower limit of PID feedback 21: analog level detection ADT1 22: analog level detection ADT2 24: undervoltage state 25: motor overheat pre-alarm 26: up to the set time 27: zero-speed running 38: off-load 39: Zero-speed running 2 40: Current reached 41: Torque reached							42: up to the speed 47: PLC output 67: Brake control 68: Material cutoff detection output 69: FDT1 lower limit (pulse) 70: FDT2 lower limit (pulse) 71: FDT1 lower limit (pulse, invalid in JOG) 72: FDT2 lower limit (pulse, invalid in JOG) 73: Overcurrent status			
F03.05	Options of output signal type	D7	D6	D5	D4	D3	D2	D1	D0		0000	○
		*	*	*	*	R2	R1	Y2	Y1			
		0: level 1: single pulse										
F03.06	Positive/negative logic of digital output	D7	D6	D5	D4	D3	D2	D1	D0		000000	○
		*	R4	R3	*	R2	R1	Y2	Y1			
		0: positive logic is valid in the closed state/invalid in the open state 1: negative logic is valid in the closed state/invalid in the open state										
F03.07	Options of Y2 output type	0: ordinary digital output 1: high frequency pulse output								0	○	
F03.08	Output status control in jog	D7	D6	D5	D4	D3	D2	D1	D0		00000	○
		*	*	*	REV	FDT 2	FDT 1	FAR	RUN			
		0: valid in jogging 1: invalid in jogging										
F03.09	Y1 valid delay time	0.00~650.00							s	0.00	●	
F03.10	Y1 invalid delay time	0.00~650.00							s	0.00	●	
F03.11	Y2 valid delay time	0.00~650.00							s	0.00	●	
F03.12	Y2 invalid delay time	0.00~650.00							s	0.00	●	
F03.13	R1 valid delay time	0.00~650.00							s	0.00	●	
F03.14	R1 invalid delay time	0.00~650.00							s	0.00	●	
F03.15	R2 valid delay time	0.00~650.00							s	0.00	●	
F03.16	R2 invalid delay time	0.00~650.00							s	0.00	●	

User's Guide for EM760 series high-performance vector inverter

F03.17	Single pulse time of Y1 output	0.001~30.000	s	0.250	●
F03.18	Single pulse time of Y2 output	0.001~30.000	s	0.250	●
F03.19	Single pulse time of R1 output	0.001~30.000	s	0.250	●
F03.20	Single pulse time of R2 output	0.001~30.000	s	0.250	●
F03.21	Options of analog output M1	0: running frequency (absolute value) 1: set frequency (absolute value) 2: output torque (absolute value) 3: set torque (absolute value)		0	○
F03.22	Options of analog output M2			2	○
F03.23	Y2 high frequency pulse output function			11	○
4: output current 5: Output voltage 6: bus voltage 7: output power 8: AI1 9: AI2		10: AI3 11: AI4 (expansion card) 12: High frequency pulse input (100.00% corresponds to the maximum frequency, and 0.00% corresponds to the minimum frequency) 13: Communication setting 1 14: count value	15: length value 16: PID output 18: PID feedback 19: PID setting 30: Communication setting 2 31: Communication setting 3		
F03.24	Frequency corresponding to 100% of Y2 high frequency pulse output	0.00~100.00	kHz	50.00	●
F03.25	Frequency corresponding to 0% of Y2 high frequency pulse output	0.00~100.00	kHz	0.00	●
F03.26	Filtering time of Y2 high frequency pulse output	0.00~10.00	s	0.10	●
F03.27	M1 output bias	-100.0~100.0	%	0.0	●
F03.28	M1 output gain	-9.999~9.999		1.000	●
F03.29	M2 output bias	-100.0~100.0	%	0.0	●
F03.30	M2 output gain	-9.999~9.999		1.000	●
F03.31	Control logic options of PLC output terminal	D7 D6 D5 D4 D3 D2 D1 D0 * R4 R3 * R2 R1 Y2 Y1 0: no output 1: output		00000	●
F03.32	Options of R3 output function (expansion card)	For details, refer to introduction to F03.02		0	○
F03.33	Options of R4 output function (expansion card)	For details, refer to introduction to F03.02		0	○
F03.34	Output type selection of analog quantity M1	0: 0~10V 1: 4~20mA		0	○
F03.35	Output type selection of analog quantity M2	2: 0~20mA		1	○

User's Guide for EM760 series high-performance vector inverter

F04 Start/stop control parameter group					
F04.00	Start-up method	0: direct start 1: start of speed tracking		0	○
F04.01	Start frequency	0.00~50.00	Hz	0.00	○
F04.02	Start frequency hold time	0.00-60.00, 0.00 is invalid	s	0.00	○
F04.03	Starting current of DC braking	0.0 to 100.0 (100.0 = rated current of motor)	%	50.0	○
F04.04	Starting time of DC braking	0.00-30.00, 0.00 invalid	s	0.00	○
F04.06	Pre-excitation current	10.0-500.0 (100.0 = no-load current)	%	100.0	○
F04.07	Pre-excitation time	0.00-10.00	s	0.10	○
F04.08	Speed tracking mode	Ones place: Tracking start frequency 0: maximum frequency 1: stop frequency 2: power frequency Tens place: Selection of search direction 0: search only in command direction 1: Search in the opposite direction if the speed cannot be found in the command direction		01	○
F04.10	Deceleration time of speed tracking	0.1~20.0	s	2.0	○
F04.11	Speed tracking current	30.0-150.0 (100.0 = rated current of inverter)	%	50.0	○
F04.12	Speed tracking compensation gain	1.00~10.00		1.00	○
F04.14	Acceleration and deceleration mode	0: linear acceleration and deceleration 1: acceleration and deceleration of continuous S curve 2: acceleration and deceleration of intermittent S curve		0	○
F04.15	Starting time of S curve in acceleration	0.00~325.00 (F15.13=0) 0.0 ~3250.0 (F15.13=1) 0~32500 (F15.13=2)	s	1.00	●
F04.16	Ending time of S curve in acceleration		s	1.00	●
F04.17	Starting time of S curve in deceleration		s	1.00	●
F04.18	Ending time of S curve in deceleration		s	1.00	●
F04.19	Stop mode	0: slow down to stop 1: free stop		0	○
F04.20	Starting frequency of DC braking in stop	0.00 to maximum frequency F00.16	Hz	0.00	○
F04.21	DC braking current in stop	0.0 to 100.0 (100.0 = rated current of motor)	%	50.0	○
F04.22	DC braking time in stop	0.00-30.00 0.00: invalid	s	0.00	○
F04.23	Demagnetization time for DC braking in stop	0.00-30.00	s	0.50	○

User's Guide for EM760 series high-performance vector inverter

F04.24	Flux braking gain	100-200 (100: no flux braking)		100	○
F04.26	Start mode after failure/free stop	0: start according to F04.00 setting mode 1: start of speed tracking		0	○
F04.27	Second confirmation of terminal start command	0: Not required for confirmation 1: to be confirmed 2: Way 2 for no confirmation (no confirmation is made even upon fault resetting)		0	○
F04.28	Minimum valid output frequency	0.00~50.00 (0.00: function invalid)	Hz	0	○
F04.29	Zero speed check frequency	0.00~5.00	Hz	0.25	●
F04.30	Initial magnetic pole search mode of synchronous motor	0: Invalid 1: Mode 1		1	●
F05	V/F control parameter group				
F05.00	V/F curve setting	0: straight line V/F 1: multi-point broken line V/F 2: 1.3-power V/F 3: 1.7-power V/F 4: square V/F 5: VF complete separation mode ($U_d = 0, U_q = K * t$ = voltage of separation voltage source) 6: VF semi-separation mode ($U_d = 0, U_q = K * t = F/Fe * 2 * \text{voltage of separation voltage source}$)		0	○
F05.01	Frequency point F1 of multi-point VF	0.00~F05.03	Hz	0.50	●
F05.02	Voltage point V1 of multi-point VF	0.0~100.0 (100.0 = Rated voltage)	%	1.0	●
F05.03	Frequency point F2 of multi-point VF	F05.01~F05.05	Hz	2.00	●
F05.04	Voltage point V2 of multi-point VF	0.0~100.0	%	4.0	●
F05.05	Frequency point F3 of multi-point VF	F05.03 to rated frequency of motor (reference frequency)	Hz	5.00	●
F05.06	Voltage point V3 of multi-point VF	0.0~100.0	%	10.0	●
F05.07	Voltage source of VF separation mode	0: digital setting of VF separation voltage 1: AI1 2: AI2 3: AI3 4: high frequency pulse (X7) 5: PID 6: Communication setting Note: 100% is the rated voltage of the motor.		0	○
F05.08	Digital setting of VF separation voltage	0.0 to 100.0 (100.0=Rated voltage of motor)	%	0.0	●

User's Guide for EM760 series high-performance vector inverter

F05.09	Rise time of VF separation voltage	0.00~60.00	s	2.00	●
F05.10	Compensation gain of V/F stator voltage drop	0.00~200.00	%	100.00	●
F05.11	V/F slip compensation gain	0.00~200.00	%	100.00	●
F05.12	V/F slip filtering time	0.00~10.00	s	1.00	●
F05.13	Oscillation suppression gain	0~20000		100	●
F05.14	Oscillation suppression cutoff frequency	0.00~600.00	Hz	55.00	●
F05.15	Droop control frequency	0.00~10.00	Hz	0.00	●
F05.16	Energy saving rate	0.00~50.00	%	0.00	●
F05.17	Energy saving action time	1.00~60.00	s	5.00	●
F05.18	Flux compensation gain of synchronous motor	0.00~500.00	%	100.00	●
F05.19	Filtering time constant of flux compensation of synchronous motor	0.00~10.00	s	0.50	●
F05.20	Change rate of VF separate power supply setting	-50.00~50.00	%	0.00	●
F06	Vector control parameter group				
F06.00	Speed proportional gain ASR_P1	0.00~100.00		12.00	●
F06.01	Speed integral time constant ASR_T1	0.000~30.000 0.000: no integral	s	0.250	●
F06.02	Speed proportional gain ASR_P2	0.00~100.00		10.00	●
F06.03	Speed integral time constant ASR_T2	0.000~30.000 0.000: no integral	s	0.300	●
F06.04	Switching frequency 1	0.00 to switching frequency 2	Hz	5.00	●
F06.05	Switching frequency 2	Switching frequency 1 to maximum frequency F00.16	Hz	10.00	●
F06.07	Filtering time constant of speed loop output	0.000~0.100	s	0.001	●
F06.08	Vector control slip gain	10.00~200.00	%	100.00	●
F06.09	Upper limit source selection of speed control torque	0: set by F06.10 and F06.11 1: AI1 2: AI2 3: AI3 4: AI4 (expansion card) 5: Communication setting (percentage) 6: Take the maximum values of AI2 and AI3 7: Take the minimum values of AI2 and AI3		0	○
F06.10	Upper limit of speed control motor torque	0.0~250.0	%	165.0	●

User's Guide for EM760 series high-performance vector inverter

F06.11	Upper limit of speed control brake torque	0.0~250.0	%	165.0	●
F06.12	Excitation current proportional gain ACR-P1	0.00~100.00		0.50	●
F06.13	Excitation current integral time constant ACR-T1	0.00~600.00 0.00: no integral	ms	10.00	●
F06.14	Torque current proportional gain ACR-P2	0.00~100.00		0.50	●
F06.15	Torque current integral time constant ACR-T2	0.00~600.00 0.00: no integral	ms	10.00	●
F06.17	SVC zero-frequency processing	0: braking 1: not processed 2: seal the tube		2	○
F06.18	SVC zero-frequency braking current	50.0-400.0 (100.0 is the no-load current of the motor)	%	100.0	○
F06.20	Voltage feedforward gain	0~100	%	0	●
F06.21	Flux weakening control options	<p>Asynchronous motor</p> <p>Ones place: Asynchronous flux weakening mode</p> <p>0: No PI adjustment output Non-zero: PI adjustment output</p> <p>Tens place: Output voltage limiting method of asynchronous motor in the flux weakening mode</p> <p>0: F06.22 output voltage limiting according to bus voltage 1: F06.22 output voltage limiting according to rated voltage</p> <p>Synchronous motor</p> <p>Ones place: Synchronous motor flux weakening mode</p> <p>1: Invalid 1: direct calculation 2: automatic adjustment</p> <p>Tens place: Output voltage limiting method of synchronous motor in the flux weakening mode</p> <p>0: F06.22 output voltage limiting according to bus voltage 1: F06.22 output voltage limiting according to rated voltage</p>		1	○
F06.22	Flux weakening voltage	70.00~100.00	%	100.00	●
F06.23	Maximum flux weakening current of synchronous motor	0.0-150.0 (100.0 is the rated current of the motor)	%	100.0	●
F06.24	Proportional gain of flux	0.00~60.00		0.50	●

User's Guide for EM760 series high-performance vector inverter

	weakening regulator				
F06.25	Integral time of flux weakening regulator	0.001~6.000	s	0.200	●
F06.26	MTPA control options of synchronous motor	0: Invalid 1: valid		1	○
F06.27	Self-learning gain at initial position	0~200	%	100	●
F06.28	Frequency of low frequency band of injection current	0.00-100.00 (100.00 is the rated frequency of the motor)	%	10.00	●
F06.29	Injection current of low frequency band	0.0-200.0 (100.0 is the rated current of the motor)	%	40.0	●
F06.30	Regulator gain of low frequency band of injection current	0.00~10.00		0.50	●
F06.31	Regulator integral time of low frequency band of injection current	0.00~300.00	ms	10.00	●
F06.32	Frequency of high frequency band of injection current	0.00-100.00 (100.00 is the rated frequency of the motor)	%	20.00	●
F06.33	Injection current f high frequency band	0.0-30.0 (100.0 is the rated current of the motor)	%	8.0	●
F06.34	Regulator gain of high frequency band of injection current	0.00~10.00		0.50	●
F06.35	Regulator integral time of high frequency band of injection current	0.00~300.00	ms	10.00	●
F06.36	Magnetic saturation coefficient of synchronous motor	0.00~1.00		0.60	○
F06.37	Stiffness coefficient of speed loop	0~20		11	●
F06.40	Amplitude of injected reactive current of synchronous motor	-50.0~+50.0	%	10.0	○
F06.41	Open-loop low-frequency processing of synchronous motor	0: VF 1: IF 2: IF in start and VF in stop 3: Throughout SVC		0	○
F06.42	Open-loop low-frequency processing range of synchronous motor	0.0~50.0	%	8.0	○
F06.43	IF injection current	0.0~600.0	%	80.0	○
F06.44	Time constant of pull-in current of magnetic pole	0.0~6000.0	ms	1.0	○

User's Guide for EM760 series high-performance vector inverter

F06.45	Initial lead angle of magnetic pole	0.0~359.9	°	0.0	○
F06.46	Speed tracking proportional gain of synchronous motor	0.00~10.00		1.00	○
F06.47	Speed tracking integral gain of synchronous motor	0.00~10.00		1.00	○
F06.48	Filtering time constant of speed tracking of synchronous motor	0.00~10.00	ms	0.40	○
F06.49	Speed tracking control intensity of synchronous motor	1.0~100.0		5.0	○
F06.50	Speed tracking control threshold of synchronous motor	0.00~10.00		0.20	○
F06.51	Rise time of injected active current of synchronous motor	0.1~50.0	s	5.0	○
F06.52	Linear transition code value of compensation in dead zone	1~1000		15	○
F06.53	Excitation current setting for frequency switching from F3 to F4	0.0~100.0	%	50.0	●
F06.54	Switching frequency 3	0.00~50.00	HZ	6.00	○
F06.55	Switching frequency 4	0.00~60.00	HZ	10.00	○
F06.56	Steady load torque and current setting	0.0~150.0	%	30.0	○
F06.57	Filtering time constant of current	0.001~5.000	ms	0.350	○
F06.58	Start injection pulse width	0.020~5.000	ms	0.050	○
F06.59	Switching frequency 1	0.00~F06.60	HZ	0.00	○
F06.60	Switching frequency 2	0.00~(F06.54/2)	HZ	1.00	○
F06.61	Current setting for self-learning at the initial position	0.10~1.25		0.90	○
F06.62	Speed ring proportion for rotation self-learning	0.00~100.00		2.00	○
F06.63	Speed ring integral time for rotation self-learning	0.000~30.000	s	0.150	○
F06.64	Acceleration time for rotation self-learning	5.00~100.00	s	20.00	○
F06.65	Deceleration time for rotation self-learning	5.00~100.00	s	20.00	○

User's Guide for EM760 series high-performance vector inverter

F06.66	Asynchronous motor type selection	0: Built-in permanent magnet synchronous motor 1: Surface-mounted permanent magnet synchronous motor 2: Permanent magnet direct drive motor		0	○
F06.67	Excitation current MTPA calculation gain	0.0~300.0	%	20.0	●
F06.68	Excitation current flux weakening calculation gain	0.0~300.0	%	20.0	●
F06.69	Start compensation angle	0~360	°	0	○
F06.70	Expanded counter electrodynamic potential filtering factor 1	0.000~1.732		0.279	●
F06.71	Expanded counter electrodynamic potential filtering factor 2	0.000~1.732		0.578	●
F06.72	Minimum estimated frequency of synchronous motor SVC	0.01~100.00	Hz	0.50	○
F06.73	Low frequency band ID-specific gain	0~500.0	%	100.0	●
F06.74	Smooth switching times	1~1000		20	●
F06.75	Speed toggle-hold times	1~2000		100	●
F06.76	Low-speed correction factor of stator resistor of asynchronous motor	10.0~500.0	%	100.0	●
F06.77	Low speed correction factor of rotor resistor of asynchronous motor	10.0~500.0	%	100.0	●
F06.78	Slip gain switching frequency of asynchronous motor	0.10~Fmax	Hz	5.00	○
F06.79	Speed ring differential time constant ASR_Td1	0.000~10.000	S	0	●
F06.80	Speed ring differential time constant ASR_Td2	0.000~10.000	S	0	●
F06.81	Speed ring differential limit	0.0~150.0	%	0	●
F06.82	Filtering time constant of bus voltage	0.0~1500.0	ms	8.0	●
F07	Protection function setting group				
F07.00	Protection shield	E20 E22 E13 E06 E05 E04 E07 E08		00000000	○
		0: valid protection 1: shielded protection			
F07.01	Motor overload protection	0.20~10.00		1.00	●

User's Guide for EM760 series high-performance vector inverter

	gain				
F07.02	Motor overload pre-alarm coefficient	50~100	%	80	●
F07.03	Motor temperature sensor type	0: No temperature sensor 1: PT100 2: PT1000 3: KTY84-130/150 4: PTC-130/150		0	●
F07.04	Motor overheat protection threshold	0~200	°C	110	●
F07.05	Motor overheat pre-alarm threshold	0~200	°C	90	●
F07.06	Bus voltage control options	Ones place: Instantaneous stop/no-stop function options 0: Invalid 1: deceleration 2: deceleration to stop Tens place: Overvoltage stall function options 0: Invalid 1: valid		10	○
F07.07	Voltage of overvoltage stall control	110.0~150.0 (380V, 100.0=537V)	%	134.1	○
F07.08	Instantaneous stop/no-stop operating voltage	60.0 to instantaneous stop/no-stop recovery voltage (100.0 = standard bus voltage)	%	76.0	○
F07.09	Instantaneous stop/no-stop recovery voltage	Instantaneous stop/no-stop recovery voltage~100.0	%	86.0	○
F07.10	Check time for instantaneous stop/no-stop recovery voltage	0.00~100.0	s	0.50	○
F07.11	Current limit control	0: Invalid 1: limit mode 1 2: limit mode 2		2	○
F07.12	Current limit level	20.0-180.0 (100.0 = the rated current of inverter)	%	150.0	●
F07.13	Quick current limit options	0: Invalid 1: valid		0	○
F07.14	Number of retries after failure	0~20, 0: disable retry after failure		0	○
F07.15	Options of digital output action in retries after failure	0: no action 1: action		0	○
F07.16	Interval of retries after failure	0.01~30.00	s	0.50	●
F07.17	Restoration time in retries after failure	0.01~30.00	s	10.00	●
F07.18	Options of retries after	E08 * E07 * E02 E06 E05 E04		000000	○

User's Guide for EM760 series high-performance vector inverter

	failure	0: allow retry after failure 1: disable retry after failure			
F07.19	Action option 1 after failure	E21 E16 E15 E14 E13 E12 E08 E07 0: free stop 1: stop according to stop mode		00000000	○
F07.20	Action option 2 after failure	E28 E27 E25 E23 0: free stop 1: stop according to stop mode		0000	○
F07.21	Options of load loss protection	0: Invalid 1: valid		0	●
F07.22	Load loss detection level	0.0~100.0	%	20.0	●
F07.23	Load loss detection time	0.0~60.0	s	1.0	●
F07.24	Options of load loss protection action	0: free stop 1: stop according to stop mode		1	○
F07.25	Motor overspeed detection level	0.0-50.0 (reference: maximum frequency F00.16)	%	20.0	●
F07.26	Motor overspeed detection time	0.0-60.0, 0.0: disable motor overspeed protection	s	1.0	●
F07.27	AVR function	0: Invalid 1: valid	%	1	○
F07.28	Stall fault detection time	0.0-6000.0 (0.0: no stall fault detection)	s	0.0	○
F07.29	Stall control intensity	0~100	%	20	○
F07.30	Instantaneous stop/no-stop deceleration time	0.00~300.00	S	20.00	○
F07.32	Options of retries after failure 2	E10 E13 E15 E16 * E19 E20 * 0: allow retry after failure 1: disable retry after failure		11111111	○
F07.34	Encoder disconnection detection percentage	0~150.0	%	100.0	○
F07.35	Protection shield 2	* * * * * * * E18 E81 0: valid protection 1: shielded protection		00	○
F07.36	Options of retries after failure 3	* * * * * * * E09 E17 0: allow retry after failure 1: disable retry after failure		11	○
F07.37	Initial voltage for saving upon power disconnection	60.0~F07.38	%	76.0	○
F07.38	Electrification voltage reading and determination	F07.37~100.0	%	86.0	○
F07.39	Delay time of electrification reading and determination	0~100.0	S	5.00	○
F07.40	Delay time of steady undervoltage determination	50~6000	ms	20	○
F07.41	Selection of input phase loss	0: Software detection		0	○

User's Guide for EM760 series high-performance vector inverter

	detection method	1: Hardware detection 2: Simultaneous software and hardware detection			
F07.42	Setting value of current for determining short to ground	0.00~100.0	%	20.0	○
F07.43	Warning shield	* * * * * C32 C31 C30 0: Warning valid 1: Warning shielded		00000000	○
F07.44	Upper limit of current for output phase loss detection	10.0~100.0	%	30.0	○
F07.45	Times of output phase loss detection	1~60000		10	○
F07.46	Times of determining ILP hardware detection	5~10000		100	●
F07.47	Soft start disconnection delay time	20~1000	mS	400	○
F08	Multi-segment speed and simple PLC				
F08.00	Multi-segment speed 1	0.00 to maximum frequency F00.16	Hz	0.00	●
F08.01	Multi-segment speed 2	0.00 to maximum frequency F00.16	Hz	5.00	●
F08.02	Multi-segment speed 3	0.00 to maximum frequency F00.16	Hz	10.00	●
F08.03	Multi-segment speed 4	0.00 to maximum frequency F00.16	Hz	15.00	●
F08.04	Multi-segment speed 5	0.00 to maximum frequency F00.16	Hz	20.00	●
F08.05	Multi-segment speed 6	0.00 to maximum frequency F00.16	Hz	25.00	●
F08.06	Multi-segment speed 7	0.00 to maximum frequency F00.16	Hz	30.00	●
F08.07	Multi-segment speed 8	0.00 to maximum frequency F00.16	Hz	35.00	●
F08.08	Multi-segment speed 9	0.00 to maximum frequency F00.16	Hz	40.00	●
F08.09	Multi-segment speed 10	0.00 to maximum frequency F00.16	Hz	45.00	●
F08.10	Multi-segment speed 11	0.00 to maximum frequency F00.16	Hz	50.00	●
F08.11	Multi-segment speed 12	0.00 to maximum frequency F00.16	Hz	50.00	●
F08.12	Multi-segment speed 13	0.00 to maximum frequency F00.16	Hz	50.00	●
F08.13	Multi-segment speed 14	0.00 to maximum frequency F00.16	Hz	50.00	●
F08.14	Multi-segment speed 15	0.00 to maximum frequency F00.16	Hz	50.00	●
F08.15	Simple PLC running mode	0: stop after a single run 1: stop after a limited number of cycles 2: run at the last segment after a limited number of cycles 3: continuous cycles		0	●
F08.16	Limited number of cycles	1~10000		1	●
F08.17	Simple PLC memory options	Ones place: Stop memory options Tens place: Power-down memory options		0	●

User's Guide for EM760 series high-performance vector inverter

		0: no memory (from the first segment) 1: Memory (from the power-down moment)			
F08.18	Simple PLC time unit	0: s (second) 1: min (minute)		0	●
F08.19	Setting of the first segment	Ones place: Running direction options 0: forward 1: reverse Tens place: Acceleration and deceleration time options 0: acceleration and deceleration time 1 2: acceleration and deceleration time 3 1: acceleration and deceleration time 2 3: acceleration and deceleration time 4		0	●
F08.20	Running time of the first segment	0.0~6000.0	s/min	5.0	●
F08.21	Setting of the second segment	Same as F08.19		0	●
F08.22	Running time of the second segment	0.0~6000.0	s/min	5.0	●
F08.23	Setting of the third segment	Same as F08.19		0	●
F08.24	Running time of the third segment	0.0~6000.0	s/min	5.0	●
F08.25	Setting of the fourth segment	Same as F08.19		0	●
F08.26	Running time of the fourth segment	0.0~6000.0	s/min	5.0	●
F08.27	Setting of the fifth segment	Same as F08.19		0	●
F08.28	Running time of the fifth segment	0.0~6000.0	s/min	5.0	●
F08.29	Setting of the sixth segment	Same as F08.19		0	●
F08.30	Running time of the sixth segment	0.0~6000.0	s/min	5.0	●
F08.31	Setting of the seventh segment	Same as F08.19		0	●
F08.32	Running time of the seventh segment	0.0~6000.0	s/min	5.0	●
F08.33	Setting of the eighth segment	Same as F08.19		0	●
F08.34	Running time of the eighth segment	0.0~6000.0	s/min	5.0	●
F08.35	Setting of the ninth segment	Same as F08.19		0	●
F08.36	Running time of the ninth segment	0.0~6000.0	s/min	5.0	●
F08.37	Setting of the tenth segment	Same as F08.19		0	●
F08.38	Running time of the tenth	0.0~6000.0	s/min	5.0	●

User's Guide for EM760 series high-performance vector inverter

	segment				
F08.39	Setting of the eleventh segment	Same as F08.19		0	●
F08.40	Running time of the eleventh segment	0.0~6000.0	s/min	5.0	●
F08.41	Setting of the twelfth segment	Same as F08.19		0	●
F08.42	Running time of the twelfth segment	0.0~6000.0	s/min	5.0	●
F08.43	Setting of the thirteenth segment	Same as F08.19		0	●
F08.44	Running time of the thirteenth segment	0.0~6000.0	s/min	5.0	●
F08.45	Setting of the fourteenth segment	Same as F08.19		0	●
F08.46	Running time of the fourteenth segment	0.0~6000.0	s/min	5.0	●
F08.47	Setting of the fifteenth segment	Same as F08.19		0	●
F08.48	Running time of the fifteenth segment	0.0~6000.0	s/min	5.0	●
F09	PID function group				
F09.00	PID setting source	0: digital PID setting4: AI4 (expansion card) 1: AI1 5: PULSE, high-frequency pulse (X7) 2: AI2 : Communication setting 3: AI3		0	○
F09.01	Digital PID setting	0.0 to PID setting feedback range F09.03		0.0	●
F09.02	PID feedback source	1: AI1 5: PULSE, high-frequency pulse (X7) 2: AI2 6: Communication setting 3: AI3 7: retention 4: AI4 (expansion card)8: output torque		1	○
F09.03	PID setting feedback range	0.1~6000.0		100.0	●
F09.04	PID positive and negative action selection	Ones place: 0: positive 1: negative Tens place: Direction selection of positive and negative action follow-up command 0: Not follow 1: Follow		0	○
F09.05	Proportional gain 1	0.00~100.00		0.40	●
F09.06	Integral time 1	0.000 - 30.000, 0.000: no integral	s	10.000	●
F09.07	Differential time 1	0.000~30.000	ms	0.000	●
F09.08	Proportional gain 2	0.00~100.00		0.40	●

User's Guide for EM760 series high-performance vector inverter

F09.09	Integral time 2	0.000 - 30.000, 0.000: no integral	s	10.000	●
F09.10	Differential time 2	0.000~30.000	ms	0.000	●
F09.11	PID parameter switching conditions	0: no switching 1: switching via digital input terminal 2: automatic switching according to deviation		0	●
F09.12	PID parameter switching deviation 1	0.00~F09.13	%	20.00	●
F09.13	PID parameter switching deviation 2	F09.12~100.00	%	80.00	●
F09.14	Initial PID value	0.00~100.00	%	0.00	●
F09.15	PID initial value holding time	0.00~650.00	s	0.00	●
F09.16	Upper limit of PID output	F09.17~+100.0	%	100.0	●
F09.17	Lower limit of PID output	-100.0~F09.16	%	0.0	●
F09.18	PID deviation limit	0.00-100.00 (0.00: invalid)	%	0.00	●
F09.19	PID differential limit	0.00~100.00	%	5.00	●
F09.20	PID integral separation threshold	0.00-100.00 (100.00% = invalid integral separation)	%	100.00	●
F09.21	PID setting change time	0.000~30.000	s	0.000	●
F09.22	PID feedback filtering time	0.000~30.000	s	0.000	●
F09.23	PID output filtering time	0.000~30.000	s	0.000	●
F09.24	Upper limit detection value of PID feedback disconnection	0.00-100.00; 100.00 = invalid feedback disconnection	%	100.00	●
F09.25	Lower limit detection value of PID feedback disconnection	0.00-100.00; 0.00 = invalid feedback disconnection	%	0.00	●
F09.26	Detection time of PID feedback disconnection	0.000~30.000	s	0.000	●
F09.27	PID sleep control options	0: Invalid 1: sleep at zero speed 2: sleep at lower frequency limit 3: sleep with tube sealed		0	●
F09.28	Sleep action point	0.00-100.00 (100.00 corresponds to the PID setting feedback range)	%	100.00	●
F09.29	Sleep delay time	0.0~6500.0	s	0.0	●
F09.30	Wake-up action point	0.00-100.00 (100.00 corresponds to the PID setting feedback range)	%	0.00	●
F09.31	Wake-up delay time	0.0~6500.0	S	0.0	●
F09.32	Multi-segment PID setting 1	0.0 to PID setting feedback range F09.03		0.0	●
F09.33	Multi-segment PID setting 2	0.0 to PID setting feedback range F09.03		0.0	●
F09.34	Multi-segment PID setting 3	0.0 to PID setting feedback range F09.03		0.0	●
F09.35	Lower limit of feedback voltage	Lower limit of feedback voltage to 10.00	V	10.00	●

User's Guide for EM760 series high-performance vector inverter

F09.36	Upper limit of feedback voltage	0.00 to upper limit of feedback voltage	V	0.00	●
F09.37	Options of integral action within the set change time of PID	0: Always calculate the integral term 1: Calculate the integral term after the F09.21 set time is reached 2: Calculate the integral term when the error is less than F09.38		0	●
F09.38	Input deviation of integral action within the set change time of PID	0.00~100.00	%	30	●
F09.39	Wake-up option	0: target pressure F09.01* coefficient of wake-up action point 1: Wake-up action point (F09.30)		0	○
F09.40	Coefficient of wake-up action point	0.0-100.0 (100% corresponds to PID setting)	%	90.0	●
F09.41	Pipeline network alarm overpressure	0.0 to pressure sensor range F09.03	bar	6.0	●
F09.42	Overpressure protection time	0-3600 (0: invalid)	s	0	●
F09.43	PID reverse limit	0: Invalid 1: valid		0	○
F10	Communication function group				
F10.00	Local Modbus communication address	1-247; 0: broadcast address		1	○
F10.01	Baud rate of Modbus communication	0: 4800 3: 38400 1: 9600 4: 57600 2: 19200 5: 115200		1	○
F10.02	Modbus data format	0: 1-8-N-1 (1 start bit + 8 data bits + 1 stop bit) 1: 1-8-E-1 (1 start bit + 8 data bits + 1 even parity check bit + 1 stop bit) 2: 1-8-O-1 (1 start bit + 8 data bits + 1 odd parity check bit + 1 stop bit) 3: 1-8-N-2 (1 start bit + 8 data bits + 2 stop bits) 4: 1-8-E-2 (1 start bit + 8 data bits + 1 even parity check bit + 2 stop bits) 5: 1-8-O-2 (1 start bit + 8 data bits + 1 odd parity check bit + 2 stop bits)		0	○
F10.03	Communication timeout	0.0s-60.0s; 0.0: invalid (valid for the master-slave mode)	s	0.0	●
F10.04	Modbus response delay	1~20	ms	2	●
F10.05	Options of master-slave communication function	0: Invalid 1: valid		0	○
F10.06	Master-slave options	0: slave 1: Host (broadcast transmission)		0	○
F10.07	Data sent by host	0: output frequency 3: set torque		1	○

User's Guide for EM760 series high-performance vector inverter

		1: set frequency 4: PID setting 2: output torque 5: output current			
F10.08	Proportional factor of slave reception	0.00-10.00 (multiple)		1.00	●
F10.09	Host sending interval	0.000~30.000	s	0.200	●
F10.12	Communication address of CANopen expansion card	1~127		1	○
F10.14	Delay time of communication card process data response	0.0~200.0	ms	0.0	○
F10.15	Baud rate of communication between the expansion card and the bus	Ones place: CANopen 0: 125K 2: 500K 1: 250K 3: 1M Tens place: Reserved		23	○
F10.17~ F10.31	Selection of data type received by PZD2~PZD16	When data 65535 is displayed, it means the current PZD remains unused; when other data, say 4609, is displayed, it means the currently selected function code is F18.01 (18D=12H, 01D=01H, 1201H=4609D).		65535	○
F10.32~ F10.46	Selection of data type sent by PZD2~PZD16			65535	○
F10.47	Communication card status	Ones place: Reserved Tens place: CANopen 0: Initialization 1: Pre-operation 2: Operation 3: Stop 4: CANopen communication abnormality 5: Modbus communication abnormality 6: Factory testing Hundreds place: Reserved		000	×
F10.48	Communication card software version				×
F10.49	Quantity of process data received	1~16		2	×
F10.50	Quantity of process data sent	1~16		2	×
F10.51	Selection of address setting mode for process data	0: Keyboard setting 1: Master station configuration		0	×
F10.52	Selection of communication card manual resetting	0: Invalid 1: valid		0	×
F10.56	Options of 485 EEPROM writing	0-10: default operation (for commissioning) 11: writing not triggered (available after commissioning)		0	○
F10.57	Enabling of SCI sending timeout resetting	0: invalid resetting 1: valid resetting		1	●
F10.58	Delay time of SCI sending timeout resetting	110~10000		150	●

User's Guide for EM760 series high-performance vector inverter

F10.61	SCI response option	0: Reply to both read and write commands 1: Reply to write commands only 2: No reply to both read and write commands		0	○
F10.62	CANopen self check identification code	0~65535		0	×
F11	User-selected array (for details, refer to the user's manual or the complete function table)				
F12	Keyboard and display function group				
F12.00	M.K multi-function key options	0: ESC 1: forward jog 2: reverse jog 3: forward/reverse switching 4: quick stop 5: free stop 6: cursor movement to the left		0	○
F12.01	Options of stop function of STOP key	0: valid only in keyboard control 1: with all command channels valid		1	○
F12.02	Parameter locking	0: do not lock 1: reference input not locked 2: all locked, except for this function code		0	●
F12.03	Parameter copying	0: No operation 1: parameter upload to keyboard 2: Download parameters to inverter		0	○
F12.09	Load speed display coefficient	0.01~600.00		30.00	●
F12.10	UP/DOWN acceleration and deceleration rate	0.00: automatic rate 0.01 - 500.00	Hz/s	5.00	○
F12.11	Options of UP/DOWN offset clearing	0: do not clear 1: clear in non-running state 2: clear when UP/DOWN invalid		0	○
F12.12	Options of UP/DOWN power-down saving of offset	0: do not save 1: save (valid after the offset is modified)		1	○
F12.13	Power meter resetting	0: do not clear 1: clear		0	●
F12.14	Restoration of default setting	0: No operation 1: restoration of factory defaults (excluding the motor parameters, inverter parameters, manufacturer parameters, running and power-on time record)		0	○
F12.15	Cumulative power-on time (h)	0~65535	h	XXX	×
F12.16	Cumulative power-on time (min)	0~59	min	XXX	×
F12.17	Cumulative running time (h)	0~65535	h	XXX	×
F12.18	Cumulative running time (min)	0~59	min	XXX	×
F12.19	Rated power of inverter	0.40~650.00	kW	Depending	×

User's Guide for EM760 series high-performance vector inverter

				on the motor type	
F12.20	Rated voltage of inverter	60~690	V	Depending on the motor type	×
F12.21	Rated current of inverter	0.1~1500.0	A	Depending on the motor type	×
F12.22	Performance software S/N 1	XXX.XX		XXX.XX	×
F12.23	Performance software S/N2	XX.XXX		XX.XXX	×
F12.24	Functional software S/N 1	XXX.XX		XXX.XX	×
F12.25	Functional software S/N 2	XX.XXX		XX.XXX	×
F12.26	Keyboard software serial number 1	XXX.XX		XXX.XX	×
F12.27	Keyboard software serial number 2	XX.XXX		XX.XXX	×
F12.28	Serial No. 1	XX.XXX		XX.XXX	×
F12.29	Serial No. 2	XXXX.X		XXXX.X	×
F12.30	Serial No. 3	XXXXXX		XXXXXX	×
F12.31	LCD language options	0: Chinese 1: English		0	●
F12.32	Monitoring mode options	0: mode 0 1: mode 1		1	●
F12.33	Running status display parameter 1 of mode 1 (display parameter 5 of LED stop status)	0.00~99.99		18.00	●
F12.34	Running status display parameter 2 of mode 1 (display parameter 1 of LED stop status)	0.00~99.99		18.01	●
F12.35	Running status display parameter 3 of mode 1 (display parameter 2 of LED stop status)	0.00~99.99		18.06	●
F12.36	Running status display parameter 4 of mode 1 (display parameter 3 of LED stop status)	0.00~99.99		18.08	●
F12.37	Running status display parameter 5 of mode 1 (display parameter 4 of LED stop status)	0.00~99.99		18.09	●
F12.38	LCD large-line display parameter 1	0.00~99.99		18.00	●

User's Guide for EM760 series high-performance vector inverter

F12.39	LCD large-line display parameter 2	0.00~99.99								18.06	●
F12.40	LCD large-line display parameter 3	0.00~99.99								18.01	●
F12.41	Options of UP/DOWN zero crossing	0: prohibit zero crossing 1: allow zero crossing								0	○
F12.42	Frequency setting of digital potentiometer	0.00 to maximum frequency 00.16							HZ	0.00	×
F12.43	Digital potentiometer torque setting	0.00- Digital torque setting F13.02							%	0.0	×
F12.46	ACLlib version number									XXX.XX	×
F12.45	UP/DOWN function selection	Cha	Scop	Key	Com	High	Anal	Digi	Mult	00100010	○
		nnel	e	boar	muni	-spe	og	tal	i-seg		
		shari	Lim	d	icati	ed	quan	freq	ment		
		ng	it		on	puls	tity	uenc	spee		
		0	0	1	0	0	0	1	0		
		0: Invalid 1: valid									
F12.47	Any address	0~65535								28673	●
F13	Torque control parameter group										
F13.00	Speed/torque control options	0: Speed control 1: Torque control								0	○
F13.01	Options of torque setting source	0: digital torque setting F13.02 1: AI1 2: AI2 3: AI3 4: AI4 (expansion card) 5: high frequency pulse input (X7) 6: Communication setting (Full range of the items 1-6, corresponding to F13.02 digital torque setting)								0	○
F13.02	Digital torque setting	-200.0 to 200.0 (100.0 = the rated torque of motor)							%	100.0	●
F13.03	Multi-segment torque 1	-200.0~200.0							%	0.0	●
F13.04	Multi-segment torque 2	-200.0~200.0							%	0.0	●
F13.05	Multi-segment torque 3	-200.0~200.0							%	0.0	●
F13.06	Torque control acceleration and deceleration time	0.00~120.00							s	0.05	●
F13.08	Upper frequency limit options of torque control	0: set by F13.09 1: AI1 2: AI2 3: AI3 4: AI4 (expansion card) 5: high frequency pulse input (X7)								0	○

User's Guide for EM760 series high-performance vector inverter

		6: Communication setting (percentage) 7: Communication setting (direct frequency setting)			
F13.09	Upper frequency limit of torque control	0.00 to maximum frequency F00.16	Hz	50.00	●
F13.10	Upper frequency limit offset	0.00 to maximum frequency F00.16	Hz	0.00	●
F13.11	Static friction torque compensation	0.0~100.0	%	0.0	●
F13.12	Frequency range of static friction compensation	0.00~50.00	Hz	1.00	●
F13.13	Dynamic friction torque compensation	0.0~100.0	%	0.0	●
F13.18	Reverse speed limit options	0~100	%	100	●
F13.19	Speed priority enabling of torque control	0: Disable 1: Enable		0	●
F14	Motor 2 parameter group (for details, refer to the user's manual or the complete function table)				
F15	Auxiliary function group				
F15.00	Jog frequency	0.00 to maximum frequency F00.16	Hz	5.00	●
F15.01	Jog acceleration time	0.00~650.00 (F15.13=0) 0.0~6500.0 (F15.13=1) 0~65000 (F15.13=2)	s	5.00	●
F15.02	Jog deceleration time		s	5.00	●
F15.03	Acceleration time 2		s	15.00	●
F15.04	Deceleration time 2		s	15.00	●
F15.05	Acceleration time 3		s	15.00	●
F15.06	Deceleration time 3		s	15.00	●
F15.07	Acceleration time 4		s	15.00	●
F15.08	Deceleration time 4		s	15.00	●
F15.09	Fundamental frequency of acceleration and deceleration time		0: maximum frequency F00.16 1: 50.00Hz 2: set frequency		0
F15.10	Automatic switching of acceleration and deceleration time	0: Invalid 1: valid		0	○
F15.11	Switching frequency of acceleration time 1 and 2	0.00 to maximum frequency F00.16	Hz	0.00	●
F15.12	Switching frequency of deceleration time 1 and 2	0.00 to maximum frequency F00.16	Hz	0.00	●
F15.13	Acceleration and deceleration time unit	0:0.01s 1:0.1s 2:1s		0	○
F15.14	Frequency hopping point 1	0.00~600.00	Hz	600.00	●
F15.15	Hopping range 1	0.00~20.00, 0.00: Invalid	Hz	0.00	●
F15.16	Frequency hopping point 2	0.00~600.00	Hz	600.00	●

User's Guide for EM760 series high-performance vector inverter

F15.17	Hopping range 2	0.00~20.00, 0.00: Invalid	Hz	0.00	●
F15.18	Frequency hopping point 3	0.00~600.00	Hz	600.00	●
F15.19	Hopping range 3	0.00~20.00, 0.00: Invalid	Hz	0.00	●
F15.20	Detection width of output frequency arrival (FAR)	0.00~50.00	Hz	2.50	○
F15.21	Output frequency detection FDT1	0.00 to maximum frequency F00.16	Hz	30.00	○
F15.22	FDT1 hysteresis	-(Fmax-F15.21)~F15.21	Hz	2.00	○
F15.23	Output frequency detection FDT2	0.00 to maximum frequency F00.16	Hz	20.00	○
F15.24	FDT2 hysteresis	-(Fmax-F15.23)~F15.23	Hz	2.00	○
F15.25	Options of analog level detection ADT	0: AI1 2: AI3 1: AI2 3: AI4 (expansion card)		0	○
F15.26	Analog level detection ADT1	0.00~100.00	%	20.00	●
F15.27	ADT1 hysteresis	0.00 to F15.26 (valid down in one direction)	%	5.00	●
F15.28	Analog level detection ADT2	0.00~100.00	%	50.00	●
F15.29	ADT2 hysteresis	0.00 to F15.28 (valid down in one direction)	%	5.00	●
F15.30	Options of energy consumption braking function	0: Invalid 1: valid		0	○
F15.31	Energy consumption braking voltage	110.0~140.0 (380V,100.0=537V)	%	128.5	○
F15.32	Braking rate	20-100 (100 means that duty ratio is 1)	%	100	●
F15.33	Operating mode with set frequency less than lower frequency limit	0: running at the lower frequency limit 1: Shutdown 2: zero-speed running		0	○
F15.34	Fan control	Ones place: Fan control mode 0: running after power-on 1: running at startup 2: intelligent operation, subject to temperature control Tens place: Electrification fan control 0: Run 1 minute first and then enter the fan control mode for running 1: Directly run in the fan control mode Hundreds place: Low-speed fan running mode enabled (above 200kW) 0: Low-speed running invalid 1: Low-speed running valid		101	○
F15.35	Overmodulation intensity	1.00~1.10		1.05	●

User's Guide for EM760 series high-performance vector inverter

F15.36	Switching options of PWM modulation mode	0: invalid (7-segment PWM modulation) 1: valid (5-segment PWM modulation)		0	○
F15.37	Switching frequency of PWM modulation mode	0.00 to maximum frequency F00.16	Hz	15.00	●
F15.38	Options of dead zone compensation mode	0: no compensation 1: compensation mode 1 2: compensation mode 2		1	○
F15.39	Terminal jog priority	0: Invalid 1: valid		0	○
F15.40	Deceleration time for quick stop	0.00~650.00 (F15.13=0) 0.0~6500.0 (F15.13=1) 0~65000 (F15.13=2)	s	1.00	●
F15.41	Output power display coefficient	50.00~150.00	%	100.0	●
F15.42	Output current display coefficient	50.00~150.00	%	100.0	●
F15.43	Output voltage display coefficient	50.00~150.00	%	100.0	●
F15.44	Current reaches the detection value	0.0~300.0 (100.0% corresponds to the rated current of motor)	%	100.0	●
F15.45	Current reaches the hysteresis	0.0~F15.44	%	5.0	●
F15.46	Torque reaches the detection value	0.0~300.0 (100.0% corresponds to the rated torque of motor)	%	100.0	●
F15.47	Torque reaches the hysteresis	0.0~F15.46	%	5.0	●
F15.48	Divided frequencies of encoder	1~256		1	●
F15.49	High-frequency filtering coefficient of PG card	0~255		0	●
F15.62	PG card feedback frequency filtering time	0.000~30.000	S	0.010	●
F15.63	Speed reaches the rising limit	0.00~Fmax	HZ	30.00	●
F15.64	Speed reaches the filtering time	0~60000	Ms	500	●
F15.65	Speed reaches the falling limit	0.00~Fmax	HZ	0.00	●
F15.66	Overcurrent detection level	0.1-300.0 (0.0: no detection; 100.0%: corresponding to the rated current of motor)	%	200.0	●
F15.67	Overcurrent detection delay time	0.00~600.00	s	0.00	●
F15.68	Market Local electricity price	0.00~100.00		1.00	○
F15.69	Power-frequency load factor	30.0~200.0	%	90.0	○

User's Guide for EM760 series high-performance vector inverter

F16		Customization function group			
F16.00	Industry application	0: Universal General purpose model 3: Winding and unwinding application		0	○
F16.01	Set length	1~65535 (F16.13=0) 0.1~6553.5 (F16.13=1) 0.01~655.35 (F16.13=2) 0.001~65.535 (F16.13=3)	m	1000	●
F16.02	Pulses per meter	0.1~6553.5		100.0	●
F16.03	Set count value	F16.04~65535		1000	●
F16.04	Specified count value	1~F16.03		1000	●
F16.05	Set time of regular running	0.0~6500.0, 0.0: Invalid	min	0.0	●
F16.06	Agent password	0~65535		0	○
F16.07	Setting of cumulative power-on arrival time	0~65535, 0: disable the protection when the power-on time is up	H	0	○
F16.08	Setting of cumulative running arrival time	0~65535, 0: disable the protection when the running time is up	H	0	○
F16.09	Factory password	0~65535		XXXXXX	●
F16.10	Analog output percentage when the set length/design count is 0	0.00~100.00	%	0.00	○
F16.11	Analog output percentage when the set length/design count is the set value	0.00~100.00	%	100.00	○
F16.13	Set length resolution	0:1m 1:0.1m 2:0.01m 3:0.001m		0	○
F16.14	Slot 1 type	0: No card 1: PROFINET card 2: EtherCAT card 3: CANopen card 4~9: Reserved 10: Gain Incremental encoder PG card 11: -Gain Incremental encoder PG card with UVW 12: Rotary transformer PG card 13: SinCos PG card 14: -Gain Incremental encoder PG card with divided frequency 15~19: retention 20: IO expansion card 1 21~29: retention		XXXX	×

User's Guide for EM760 series high-performance vector inverter

		30: PLC card							
F16.15	Slot 2 type	Same with slot 1						XXXX	×
F16.16	Slot 1 software S/N 1	0.00~65.335						XXXX	×
F16.17	Slot 1 software S/N 2	0.00~65.335						XXXX	×
F16.18	Slot 2 software S/N 1	0.00~65.335						XXXX	×
F16.19	Slot 2 software S/N 2	0.00~65.335						XXXX	×
F17	Virtual I/O function group (for details, refer to the user's manual or the complete function table)								
F18	Monitoring parameter group								
F18.00	Output frequency	0.00 to upper frequency limit					Hz	0.00	×
F18.01	Set frequency	0.00 to maximum frequency F00.16					Hz	0.00	×
F18.02	PG feedback frequency	0.00 to upper frequency limit					Hz	0.00	×
F18.03	Estimate feedback frequency	0.00 to upper frequency limit					Hz	0.00	×
F18.04	Output torque	-200.0~200.0					%	0.0	×
F18.05	Torque setting	-200.0~200.0					%	0.0	×
F18.06	Output current	0.00 to 650.00 (rated power of motor: ≤ 75 kW) 0.0 to 6500.0 (rated power of motor: > 75 kW)					A	0.00	×
F18.07	Output current percentage	0.0-300.0 (100.0 = the rated current of inverter)					%	0.0	×
F18.08	Output voltage	0.0~690.0					V	0.0	×
F18.09	DC bus voltage	0~1200					V	0	×
F18.10	Simple PLC running times	0~10000						0	×
F18.11	Simple PLC operation stage	1~15						1	×
F18.12	PLC running time at the current stage	0.0~6000.0						0.0	×
F18.14	Load rate	0~65535					rpm	0	×
F18.15	UP/DOWN offset frequency	0.00 to 2 * Maximum frequency F00.16					Hz	0.00	×
F18.16	PID setting	0.0 to PID maximum range						0.0	×
F18.17	PID feedback	0.0 to PID maximum range						0.0	×
F18.18	Power meter: MWh	0~65535					MWh	0	×
F18.19	Watt-hour meter: kWh	0.0~999.9					kWh	0.0	×
F18.20	Output power	0.00~650.00					kW	0.00	×
F18.21	Output power factor	-1.000~1.000						0.000	×
F18.22	Digital input terminal status 1	X5	X4	X3	X2	X1		XXX	×
		0/1	0/1	0/1	0/1	0/1			
F18.23	Digital input terminal status 2	AI3	AI2	AI1	X5	X4		XXX	×
		0/1	0/1	0/1	0/1	0/1			
F18.24	Digital input terminal status 3	AI4	*	X10	X9	X8		XXX	×
		*	0/1	0/1	0/1	0/1			
F18.25	Output terminal state 1	*	R2	R1	Y2	Y1		XXX	×
		0/1	0/1	0/1	0/1	0/1			
F18.26	AI1	-100.0~100.0					%	0.0	×
F18.27	AI2	0.0~100.0					%	0.0	×

User's Guide for EM760 series high-performance vector inverter

F18.28	AI3	0.0~100.0				%	0.0	×
F18.29	AI4	-100.0~100.0				%	0.0	×
F18.30	Output terminal state 2	*	*	*	R3	R4	XXX	×
		0/1	0/1	0/1	0/1	0/1		
F18.31	High-frequency pulse input frequency: kHz	0.00~100.00				kHz	0.00	×
F18.32	High-frequency pulse input frequency: Hz	0~65535				Hz	0	×
F18.33	Count value	0~65535					0	×
F18.34	Actual length	0~65535				m	0	×
F18.35	Remaining time of regular running	0.0~6500.0				min	0.0	×
F18.36	Rotor position of synchronous motor	0.0~359.9°					0.0	×
F18.37	Rotary transformation location	0~4095					0	×
F18.38	Motor temperature	0~200				°C	0	×
F18.39	VF separation target voltage	0~690				V	0	×
F18.40	VF separation output voltage	0~690				V	0	×
F18.41	View any address						0	×
F18.42	Random carrier frequency display	1000~16000				HZ	0	×
F18.51	PID output	-100.0~100.0				%		×
F18.58	Feedback pulse high	0~65535					0	×
F18.59	Feedback pulse low	0~65535					0	×
F18.60	Inverter temperature	-40~200				°C	0	×
F18.67	Saved electric energy (MWH)	Cumulative energy saving MWH				MWh	0~65535	×
F18.68	Saved electric energy (KWH)	Cumulative energy saving KWH				kWh	0.0~999.9	×
F18.69	Saved electric charge (1,000 yuan)	High cumulative cost saving (*1000)					0~65535	×
F18.70	Saved electric charge (yuan)	Low cumulative cost saving					0.0~999.9	×
F18.71	Power-frequency power consumption MWh	Power-frequency power consumption MWH				MWh	0~65535	×
F18.72	Power-frequency power consumption KWh	Power-frequency power consumption KWH				kWh	0.0~999.9	×
F19	Fault record group							
F19.00	Last fault category	0: No failure Refer to Chapter 6 "Faults and Solutions" for					0	×

User's Guide for EM760 series high-performance vector inverter

		fault codes.			
F19.01	Output frequency in failure	0.00 to upper frequency limit	Hz	0.00	×
F19.02	Output current in failure	0.00 to 650.00 (rated power of motor: ≤ 75 kW) 0.0 to 6500.0 (rated power of motor: > 75 kW)	A	0.00	×
F19.03	Bus voltage in failure	0~1200	V	0	×
F19.04	Running status in failure	0: not running 4: reverse deceleration 1: forward acceleration5: constant speed in forward running 2: reverse acceleration6: reverse constant speed in reverse running 3: forward deceleration		0	×
F19.05	Working time in failure	0.00~6553	h	0	×
F19.06	Previous fault category	Same as F19.00 parameter description		0	×
F19.07	Output frequency in failure		Hz	0.00	×
F19.08	Output current in failure		A	0.00	×
F19.09	Bus voltage in failure		V	0	×
F19.10	Running status in failure	Same as F19.04 parameter description		0	×
F19.11	Working time in failure		h	0	×
F19.12	Last two fault categories	Same as F19.00 parameter description		0	×
F19.13	Output frequency in failure		Hz	0.00	×
F19.14	Output current in failure		A	0.00	×
F19.15	Bus voltage in failure		V	0	×
F19.16	Running status in failure	Same as F19.04 parameter description		0	×
F19.17	Working time in failure		h	0	×
F27	Winding and unwinding application macro parameter group (for details, refer to the user's manual or the complete function table)				
F27.00	Application macro	0: Winding mode 2: Wire drawing mode 1: Unwinding mode 3: Straight wire drawing machine mode		0	○
F45	Modbus free mapping parameter group (for details, refer to the user's manual or the complete function table)				